

NOTES:

- 1) ENCLOSURE IS LIGHT-WEIGHT DURABLE NON-CONDUCTIVE PLASTIC "TOOL-BOX" TYPE
- 2) UNIT IS SHORT-CIRCUIT PROTECTED
- 3) INTERNALLY MOUNTED FEATURES:
 - A) 120V AC INPUT CABLE, CONNECTS TO STANDARD 120VAC POWER OUTLET (6'-0" / 1.83m LONG)
 - B) COLOR-CODED DC OUTPUT BATTERY CONNECTION CABLES W/CLAMPS
 - C) DC AMMETER AND VOLTAGE ADJUSTMENT
 - D) INSTRUCTION SHEET PERMANENTLY MOUNTED TO INSIDE TOP COVER
- 4) SINGLE-CELL BATTERY CHARGER SHIPPING WEIGHT: 12 lbs. / 5.4 kg.

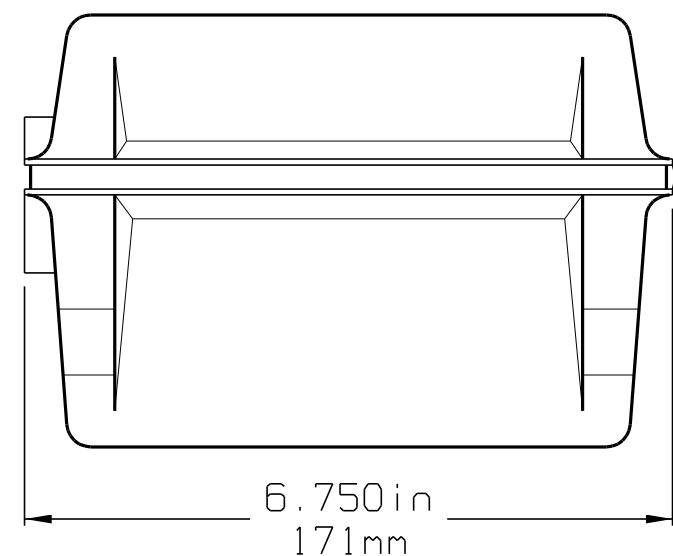

				THIRD ANGLE PROJECTION			
				DRAWN BY MCR APPROVED <i>OK</i>	040903 040903	TITLE OUTLINE: SINGLE-CELL BATTERY CHARGER	
1	20380	101806				DRAWING No JE5065-00	REV 1
0	E1207	040903	<i>OK</i>	UNLESS OTHERWISE NOTED DIMENSIONS ARE IN INCHES. TOLERANCES ARE:		B	
REV	ECN No	DATE	APP	SCALE	NTS	PART No	SHEET 1 OF 1 JE5065-00