

SIDE VIEW

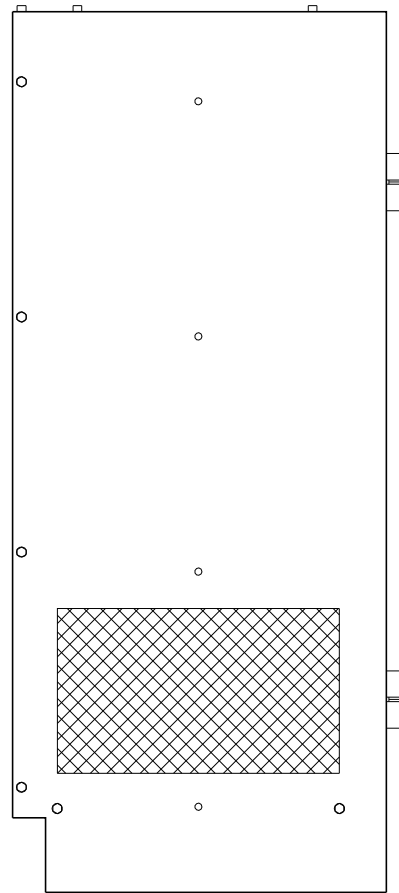

FRONT VIEW

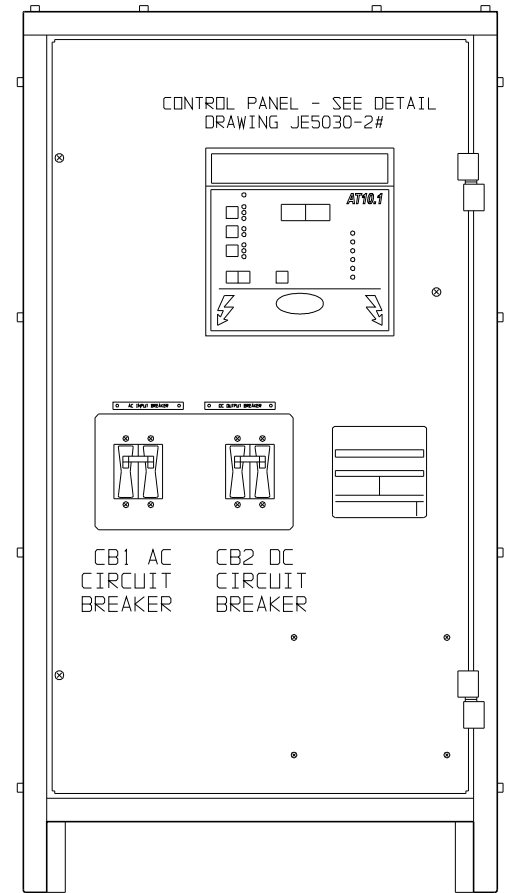

SIDE VIEW

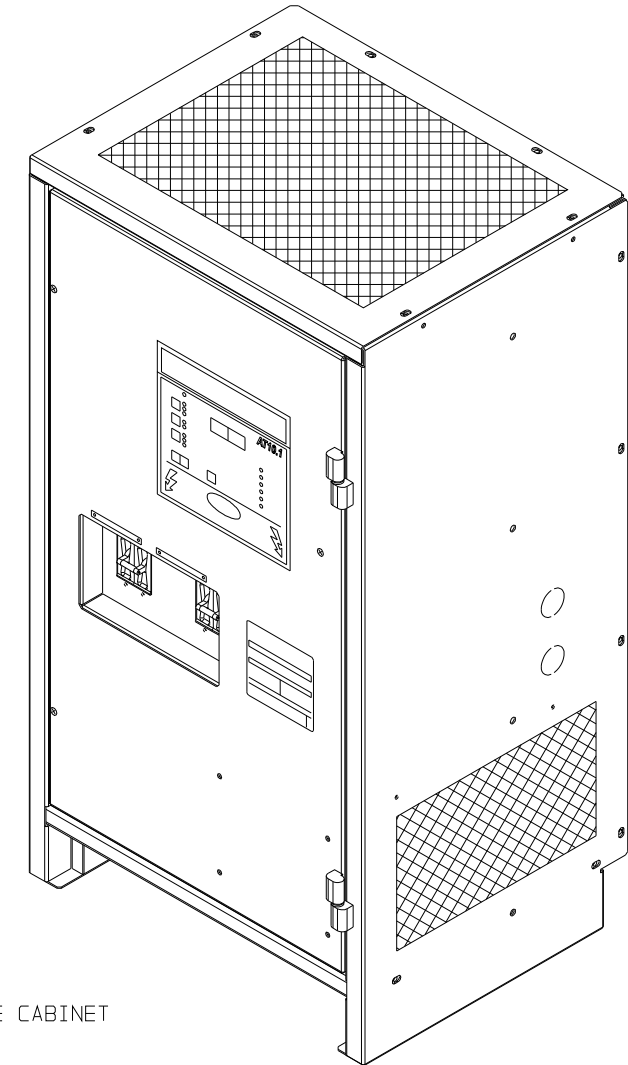
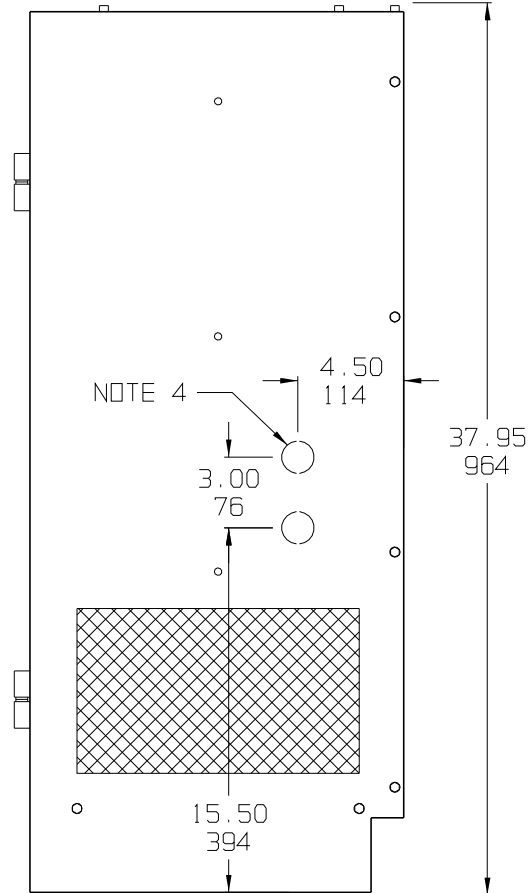

20.90
531

16.77
426

37.95
964

NOTE 4

4.50
114

3.00
76

15.50
394

NOTES:

- 1) ENCLOSURE IS A NEMA-1 TYPE CABINET WITHOUT GASKETS.
- 2) ALLOW 12in (305mm) OF FREE AIR (TOP AND FRONT OF CABINET) FOR VENTILATION.
- 3) FOUR (4) 1in x .625in (25mm x 16mm) FLOOR-MOUNTING SLOTS ARE PROVIDED ON BOTTOM OF ENCLOSURE AS SHOWN.
- 4) TWO (2) 1.31in/33mm DIA STANDARD PRE-FAB KNOCKOUTS ARE PROVIDED, SHOWN ON THE LOWER-RIGHT SIDE OF ENCLOSURE FOR UP TO 1in/25mm CONDUIT. IF ADDITIONAL CONDUIT ENTRANCES ARE REQUIRED BY USER, ENCLOSURE SHOULD BE FIELD-MODIFIED BY INSTALLER.
- 5) BATTERY CHARGER SHIPPING WEIGHT RANGE: APPROXIMATELY 205-660 lbs. / 93-300 kg.

BOTTOM VIEW

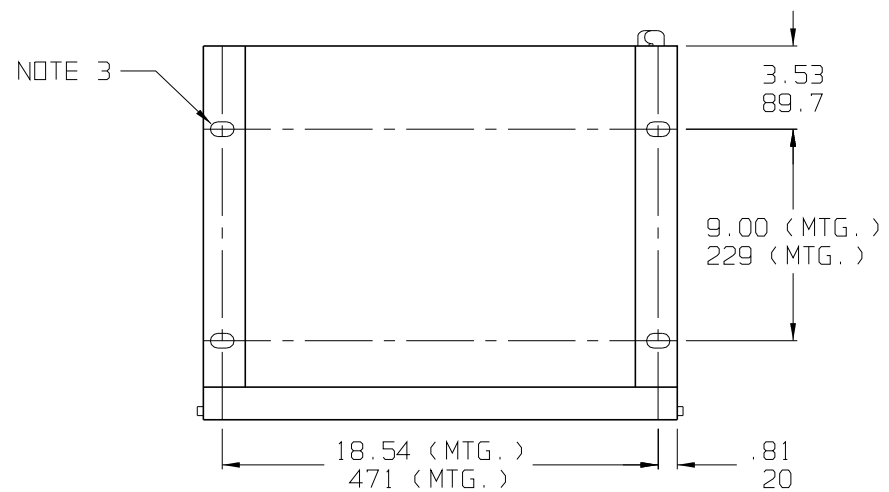

DUAL DIMENSIONS in mm

				 THIRD ANGLE PROJECTION		 800.931.4919 / 514.369.4919 / www.mdspower.com	
				DRAWN BY MCR APPROVED <i>QA</i>	022603 022603	TITLE AT10.1 SERIES BATTERY CHARGER OUTLINE: NEMA-1 STYLE-5018 ENCLOSURE	
				UNLESS OTHERWISE NOTED DIMENSIONS ARE IN INCHES. TOLERANCES ARE:		DRAWING No JE5026-00 REV 1 B	
REV	ECN No	DATE	APP	SCALE	NTS	PART No	JE5026-00 SHEET 1 OF 1