

***Operating and Service Instructions***

**AT10.1** SERIES

MICROPROCESSOR-CONTROLLED  
**FLOAT BATTERY CHARGER**

**SINGLE PHASE INPUT**

**GROUP I**  
**(6-25 A dc OUTPUT)**

**//MDSPOWER<sup>®</sup>**

P.O. Box 532, Champlain, New York 12919  
Tel: 514.369.4919 [www.mdspower.com](http://www.mdspower.com)

# HOW TO READ THE AT10.1 MODEL NUMBER

## GROUP I RATINGS (6-25 Adc)

The **AT10.1** configured model number is coded to describe the unit's features and options. Please identify the model number printed on the data nameplate decal, and write it in the spaces provided below.

<b>AT10</b>												X	X
A	B	C	D	E	F	G	H	J	K	L	M	N	

Follow the chart below to determine the configuration of the AT10.1.

DESCRIPTION	CODE	FEATURE
<b>A</b> SERIES	AT10	AT10.1 BATTERY CHARGER
<b>B</b> NOMINAL DC OUTPUT VOLTAGE	012	12 Vdc
	024	24 Vdc
	048	48 Vdc
	130	130 Vdc
<b>C</b> NOMINAL DC OUTPUT CURRENT	006	6 Adc
	012	12 Adc
	016	16 Adc
	020	20 Adc
<b>D</b> DC FILTERING	U	UNFILTERED
	F	FILTERED (STANDARD)
	E	BATT ELIMINATOR FILTER
<b>E</b> AC INPUT VOLTAGE	120	120 Vac 60 Hz <sup>1</sup>
	208	208 Vac 60 Hz <sup>1</sup>
	240	240 Vac 60 Hz <sup>1</sup>
	480	480 Vac 60 Hz
	220	220 Vac 50/60 Hz <sup>2</sup>
	380	380 Vac 50/60 Hz <sup>2</sup>
	416	416 Vac 50/60 Hz <sup>2</sup>

DESCRIPTION	CODE	FEATURE
<b>F</b> CIRCUIT BREAKER RATING (SEE TABLE)	S	STANDARD
	M	MEDIUM AIC
	H	HIGH AIC
<b>G</b> AUX ALARM RELAY BOARD	AUX	SUPPLIED
	XXX	NOT SUPPLIED
<b>H</b> COPPER GROUND BUS	G	SUPPLIED
	X	NOT SUPPLIED
<b>J</b> LIGHTNING ARRESTOR	L	SUPPLIED
	X	NOT SUPPLIED
<b>K</b> FUNGUS PROOFING	F	APPLIED
	X	NOT APPLIED
<b>L</b> STATIC PROOFING	S	APPLIED
	X	NOT APPLIED
<b>M</b> NOT USED	X	
<b>N</b> NOT USED	X	

1 - 120/208/240 Vac multi-tap input - AT10.1 is wired and shipped from factory at specified voltage.  
 2 - Special order, consult factory for availability.

## INPUT AND OUTPUT CIRCUIT BREAKER INTERRUPTING RATINGS

CODE	TYPE	AC RATINGS (ALL INPUT VOLTAGES)	DC RATINGS (125 Vdc)
S	STANDARD	240 Vac: 10,000 AIC 480 Vac: 5,000 AIC	10,000 AIC <sup>4</sup> 5,000 AIC <sup>5</sup>
M	MEDIUM AIC	240 Vac: 25,000 AIC 480 Vac: 18,000 AIC	10,000 AIC
H	HIGH AIC	240 Vac: 65,000 AIC 480 Vac: 25,000 AIC	20,000 AIC

4 - Rating applies to 130Vdc 16-25 Adc units.  
 5 - Approximate rating applies to all other units.

### NOTICE

The factory-configured model number printed on the AT10.1 data nameplate decal does not feature certain options and accessories. Nor does it feature any field-installed options. Check off below any options and/or accessories that are initially included, or are installed after shipment.

- |  |   |
|--|---|
| <input type="checkbox"/> floor/rack-mounting brackets    | <input type="checkbox"/> analog ac voltmeter (penthouse-mounted)          |
| <input type="checkbox"/> NEMA Type 2 drip shield         | <input type="checkbox"/> analog ac ammeter (penthouse-mounted)            |
| <input type="checkbox"/> NEMA Type 4 (12/13) cabinet     | <input type="checkbox"/> barrier type auxiliary alarm terminal block(s)   |
| <input type="checkbox"/> cabinet heater assembly         | <input type="checkbox"/> external temperature compensation probe          |
| <input type="checkbox"/> pad lock for front panel door   | <input type="checkbox"/> DNP3 Level 2 / Modbus communications module      |
| <input type="checkbox"/> zero-center ground detect meter | <input type="checkbox"/> forced load sharing signal interconnection cable |

Please find the serial number on the data nameplate and record it here:

# MANUFACTURER'S WARRANTY

---

## FIVE-YEAR WARRANTY

### NEW PRODUCT - BATTERY CHARGER

*[applies only to product(s) delivered within the United States and Canada]*



#### Product Details:

Battery Charger Model:	
Factory Ordering Code:	
Battery Charger Serial Number:	
Date Shipped:	
Date Energized:	

#### Standard Warranty

This product is warranted to be free from defects in material and workmanship for a period of **five (5) years** from date of manufacture.

During the term of the warranty period: parts, assemblies, or components deemed to be defective will be repaired or replaced at the manufacturer's option, free of charge. All costs related to removal, reinstallation and transportation will be paid by the purchaser/customer and/or operator of the product. Evaluation, repair and/or replacement of any defective part(s) are FOB manufacturer's factory.

This warranty does not cover products or parts that are damaged from improper use or abuse, as determined by the manufacturer. Accessory items or additional items carry only their respective manufacturer's warranty. Consumable items (such as fuses and electrolytic capacitors), which wear out under normal use are specifically not covered by this standard warranty. Any consequential damage due to diagnosis or repair by any party other than the manufacturer's authorized personnel is not covered under this warranty.

# MANUFACTURER'S WARRANTY

---

## ❑ **Extended Spare Parts Warranty**

The manufacturer's extended warranty includes all items as mentioned in the "**Standard Warranty**" as previously listed, plus reasonable in/out freight costs related to a warranty claim for parts. Said freight cost is based on either standard UPS rates or common carrier only, as appropriate. Contact your sales representative for more information & pricing regarding the extended spare parts warranty.

## ❑ **Magnetic Parts 25-Year Extended Warranty** (equal to 5% of the original purchase price)

Lifetime warranty (*limited to 25 years from date of shipment*) covers battery charger major electromagnetic components (T1 transformer, L1 inductor & L2 inductor) as applicable. Coverage is for 100% replacement of any covered magnetic component that fails during normal use. Abuse, neglect, and damage from outside sources or improper application will make this warranty null and void. The manufacturer reserves the right to make final determination regarding the application of this warranty. The manufacturer will be responsible for costs related to inbound and outbound freight of warranted magnetic components (T1, L1 & L2).

Freight cost is based on standard UPS rates or common carrier only, as appropriate. Costs related to removal and/or reinstallation of warranted magnetic components will be the responsibility of the purchaser/customer and/or operator of the product. Contact your sales representative for more information & pricing regarding the magnetic parts extended warranty.

## **NOTICE**

Requests for returns or warranty claims *must* be made via manufacturer's Return Material Authorization (RMA) instructions and assignment.

Contact your sales representative for more information & pricing regarding returns or warranty claims. Returns that do not follow this procedure will not be honored.

Election to any of the above offered extended warranties must be done within the terms of the initial standard warranty.

## PLEASE READ AND FOLLOW ALL SAFETY INSTRUCTIONS

### NOTICE

1. Before using the AT10.1, read all instructions and cautionary markings on:  
A) this equipment, B) battery, and C) any other equipment to be used in conjunction with the AT10.1.
2. This manual contains important safety and operating instructions, and should therefore be filed for easy access.
3. Remove all jewelry, watches, rings, etc. before proceeding with installation or service.
4. Maintain at least 6in / 152mm of free air on all vented surfaces for cooling. Allow sufficient clearance to open the front panel for servicing.
5. Connect or disconnect the battery only when the AT10.1 is off, to prevent arcing or burning.
6. Do not operate the AT10.1 if it has been damaged in any way. Refer to qualified service personnel.
7. Do not disassemble the AT10.1. Only qualified service personnel should attempt repairs. Incorrect reassembly may result in explosion, electrical shock, or fire.
8. Do not install the AT10.1 outdoors, or in wet or damp locations, unless specifically ordered for that environment.
9. Do not use the AT10.1 for *ANY* purpose not described in this manual.

### WARNING

1. Do not touch any uninsulated parts of the AT10.1, especially the input and output connections, as there is the possibility of electrical shock.
2. During normal operation, batteries may produce explosive gas. Never smoke, use an open flame, or create arcs in the vicinity of the AT10.1 or the battery.
3. Turn the AT10.1 off before connecting or disconnecting the battery to avoid shock hazards and/or equipment damage.
4. De-energize and lock out all ac and dc power sources to the AT10.1 before servicing.
5. Do not operate the AT10.1 with any power source that does not match the specified ac and dc voltage ratings. Refer to the data nameplate decal affixed to the outside panel for operational requirements.
6. Do not operate the AT10.1 with the Plexiglas safety shield or any other supplied guards removed or improperly installed.

# TABLE OF CONTENTS

---

HOW TO READ THE AT10.1 MODEL NUMBER.....	Inside Front Cover
MANUFACTURER'S WARRANTY.....	Removable Form
IMPORTANT SAFETY INSTRUCTIONS.....	i

## 1 Receiving and Installing the AT10.1 Battery Charger

1.1 Storing the AT10.1.....	2
1.2 Reporting shipping damage.....	2
1.3 Unpacking and inspecting the AT10.1.....	2
<i>Inspection checklist</i> .....	2
1.4 Moving the AT10.1.....	3
<i>Enclosure type and weight table</i> .....	3
1.5 Mounting the AT10.1.....	3
1.5.1 Wall-Mounting the AT10.1.....	4
1.5.2 Floor-Mounting the AT10.1.....	6
1.5.3 Rack-Mounting the AT10.1.....	8
1.6 Changing transformer taps.....	10
1.7 Making the ac input connections.....	12
1.8 Making the dc output connections.....	14
1.9 Wiring the AT10.1 for remote sensing.....	16
1.10 Wiring to the remote alarm contacts.....	18
<i>Auxiliary Alarm Relay PC Board (optional)</i> .....	19
1.11 Installing the temperature compensation assembly (optional).....	20
<i>Using temperature compensation</i> .....	22
1.12 Installing the AT10.1 for remote communications (optional).....	23
1.13 Installing the AT10.1 for forced load sharing (optional).....	23

## 2 Operating the AT10.1 Battery Charger

2.1 Starting the AT10.1	
2.1.1 Understanding the start-up sequence.....	24
2.1.2 Checking the installation.....	24
2.1.3 Starting the AT10.1.....	24
<i>Using the digital meter</i> .....	24
<i>Factory settings table</i> .....	25
2.2 Using the AT10.1 front panel features	
2.2.1 If the meter displays an error message.....	26
2.2.2 Selecting the meter mode.....	26
2.2.3 Selecting the Float or Equalize mode.....	27
2.2.4 Choosing the Equalize method.....	27
<i>Manual Timer method</i> .....	27
<i>Manual Equalize method</i> .....	28
<i>Auto-Equalize Timer method</i> .....	28
2.2.5 Testing the front panel indicators & Summary Alarm Relays.....	29
2.2.6 Testing the Auxiliary Alarm Relay PC Board.....	29
2.2.7 Interpreting the alarm indicators.....	29

# TABLE OF CONTENTS

2.3	Setting the AT10.1 parameters	
2.3.1	Understanding parameter settings .....	30
2.3.2	Setting the Float and Equalize voltages .....	31
2.3.3	Setting the Equalize timer .....	32
2.3.4	Setting the Alarms .....	32
	<i>Setting the high and low dc voltage alarms</i> .....	33
	<i>Adjusting ground detection sensitivity</i> .....	34
	<i>Disabling the ground detection alarm</i> .....	35
2.3.5	Setting the Current Limit value .....	35
2.3.6	Enabling the high dc voltage shutdown feature .....	36
2.3.7	Adjusting the Voltmeter accuracy.....	37
2.3.8	Using the Low Level Detector (LLD) .....	38
2.3.9	Using the front panel security feature .....	39
2.4	Performing routine maintenance.....	40
	<i>Sample preventive maintenance procedure</i> .....	42
<b>3</b>	<b>Servicing the AT10.1 Battery Charger</b>	
3.1	A step-by-step troubleshooting procedure .....	44
3.2	Interpreting front panel error messages.....	45
3.3	Using the troubleshooting chart .....	48
3.4	Troubleshooting chart begins on.....	49
3.5	Replacing defective components .....	58
3.6	Ordering replacement parts.....	64
	<i>Replacement parts tables (begin on)</i> .....	64
	<b>APPENDIX A: AT10.1 Performance Specifications</b> .....	<b>70</b>
	<b>APPENDIX B: Field Installable Accessories</b> .....	<b>71</b>
	<b>APPENDIX C: Standard Drawings *</b>	
	Outlines: AT10.1 Group I Batt Chgr NEMA-1 Style-586 / Style-594 Encl.....	72 / 74
	Internal Component Layout: AT10.1 Style-586/594 Encl w/Common Options .....	76
	Instrument Panel / PC Board Detail: AT10.1 Group I Battery Charger .....	78
	Schematics: AT10.1 Group I Battery Charger .....	80 / 82
	Connection Diagrams: AT10.1 Group I Battery Charger .....	84 / 86
	<b>APPENDIX D: Recommended Float/Equalize Voltages / Temp. Compensation</b> .....	<b>88</b>
	<b>APPENDIX E: Communications Module</b> .....	<b>89</b>
	<b>APPENDIX F: Forced Load Sharing</b> .....	<b>90</b>
	<b>APPENDIX G: CE Grounding Compliance / UL Data (ac branch protection)</b> .....	<b>92</b>
	<b>APPENDIX H: Remote Shutdown</b> .....	<b>93</b>
	<b>APPENDIX J: Battery Open Alarm</b> .....	<b>94</b>
	<b>MANUAL SPECIFICATIONS</b> .....	<b>96</b>
	<b>RELATED DOCUMENTS (web-based content)</b> .....	<b>97</b>

\* A *customized* record drawing package is available for your particular AT10.1, featuring an itemized internal component layout, electrical schematic with component ratings, and a full connection diagram. If the standard drawings featured in this manual are not sufficient, please contact your Sales Representative for drawing availability from the AT10.1 manufacturer.

# RECEIVING THE AT10.1

---

## 1. RECEIVING THE AT10.1

### 1.1. STORING THE AT10.1

If you store the AT10.1 for more than a few days before installation, you should store it in its original shipping container, and in a temperature controlled, dry climate. Ambient temperatures of 0 to 122 °F / -18 to 50 °C are acceptable. Storage should not exceed two (2) years due to the limited shelf life of the dc filter capacitors when they are not in service.

### 1.2. REPORTING SHIPPING DAMAGE

Upon delivery of the AT10.1 (or related products) if you discover any damage or shortage, make notation on all copies of delivering carrier's delivery receipt before signing and notify the delivery person of your findings. If loss or damage is discovered after delivery, notify delivering carrier immediately and request an inspection. The manufacturer does not assume any liability for damage during transportation or handling.

Should the products require an inspection by (or return to) the manufacturer, please contact your sales representative for further instructions. Any returned material must be properly packed in compliance with shipping regulations. It is preferable to use the original shipping materials if possible. Mark the outside of the shipping container with the Return Material Authorization (RMA) number issued by the manufacturer.

### 1.3. UNPACKING AND INSPECTING THE AT10.1

Carefully remove all shipping materials from the AT10.1. Remove the AT10.1 from the shipping pallet for inspection. Save all shipping materials until you are sure that there is no shipping damage.

Once the AT10.1 is unpacked, inspect the unit for possible shipping damage, using the checklist below. If shipping damage has occurred, refer to Section 1.2 on this page for proper reporting.

#### *INSPECTION CHECKLIST*

- Enclosure exterior and interior are not marred or dented.
- There is no visible damage to exterior or interior components.
- All internal components are secure.
- Printed circuit boards are firmly seated on their standoffs.
- All hardware is tight.
- All wire terminations are secure.
- The User's Manual is included.
- You received all items on the packing list.



# INSTALLING THE AT10.1

## 1.4. MOVING THE AT10.1

Once you have established that the AT10.1 is undamaged, identify the enclosure style and weight of your unit. Refer to the table below.

**AT10.1 Enclosure Style and Shipping Weight Table**  
**Group I NEMA-1 Cabinets (Style-586 / Style-594)**

Output Voltage	Ampere Rating				
	6 Adc	12 Adc	16 Adc	20 Adc	25 Adc
12 Vdc	Style-586	Style-586	Style-586	Style-586	Style-586
	44 lbs	44 lbs	67 lbs	67 lbs	67 lbs
	20 kg	20 kg	30 kg	30 kg	30 kg
24 Vdc	Style-586	Style-586	Style-586	Style-586	Style-586
	44 lbs	58 lbs	75 lbs	75 lbs	75 lbs
	20 kg	26 kg	34 kg	34 kg	34 kg
48 Vdc	Style-586	Style-586	Style-594	Style-594	Style-594
	58 lbs	75 lbs	110 lbs	110 lbs	110 lbs
	26 kg	34 kg	50 kg	50 kg	50 kg
130 Vdc	Style-586	Style-594	Style-594	Style-594	Style-594
	80 lbs	147 lbs	193 lbs	193 lbs	193 lbs
	36 kg	67 kg	88 kg	88 kg	88 kg

Actual unit weight is approximately 20 lbs / 9kg below listed shipping weight in table.

The Style-586 & Style-594 enclosures do not feature top lifting eyes for moving. Move the AT10.1 with a forklift whenever possible, using the supplied shipping pallet.

Lift the AT10.1 into a wall-mount or rack-mount installation, using a heavy-duty sling or a scissor lift.

For further AT10.1 standard cabinet information, see the outline drawings for the Style-586 ([JE5023-03](#)) and Style-594 ([JE5024-03](#)) enclosures in Appendix C on pages 72 and 74.

## 1.5. MOUNTING THE AT10.1

The AT10.1 must be installed in manner that allows easy access to the front ac (CB1) and dc (CB2) circuit breakers. Chose a mounting method for the AT10.1 enclosure from the table below.

MANUAL SECTION	MOUNTING METHOD	ENCLOSURE	
		Style-586	Style-594
1.5.1	Wall-Mounting	<b>STANDARD</b>	<b>STANDARD</b>
1.5.2	Floor-Mounting	OPTIONAL	OPTIONAL
1.5.3	19in / 483mm Rack-Mounting	OPTIONAL	N/A
	23-24in / 584-610mm Rack-Mounting	OPTIONAL	OPTIONAL

# INSTALLING THE AT10.1

---

## 1.5.1. Wall-Mounting the AT10.1

Wall-mounting is the standard means of installing the AT10.1 Group I enclosures. When wall-mounting the AT10.1, consider the following:

1. Refer to the outline drawings for the Style-586 ([JE5023-03](#)) and Style-594 ([JE5024-03](#)) enclosures in Appendix C on pages 72 and 74.
2. The wall must be strong enough to properly support the weight of the AT10.1, plus a safety factor. See the Weight Table featured in Section 1.4 on page 3. The weight of your AT10.1 may be different, depending on the feature, options, and accessories ordered with the unit.
3. Be conscious of planned ac input and dc output wiring to the AT10.1, selecting conduit entrances carefully. Use of the pref-fab knockouts on the sides or bottom of the enclosure will allow removal of the cabinet shroud (and internal access for servicing) without removal of the unit from the wall.
4. The location:
  - Should be free of drips and splatter. If falling particles and liquids are a problem, install a NEMA-2 type drip shield accessory ([EI0191-00](#)). For kit availability, see ordering information in Appendix B on page 71.
  - Should be between 0 and 122 °F / -18 and 50 °C, with relative humidity between 5% and 95% non-condensing.
  - Must be free of flammable or explosive materials.
5. Maintain at least 6in / 152mm of free air on all vented surfaces for cooling.
6. Allow at least 36in / 914mm front clearance for access to the AT10.1 for operation and maintenance.

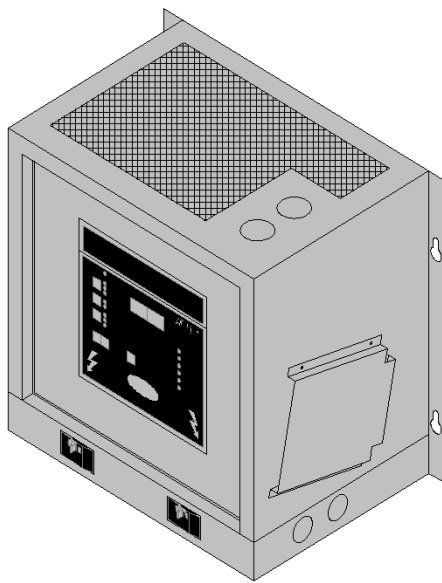

**Style-586 Enclosure**

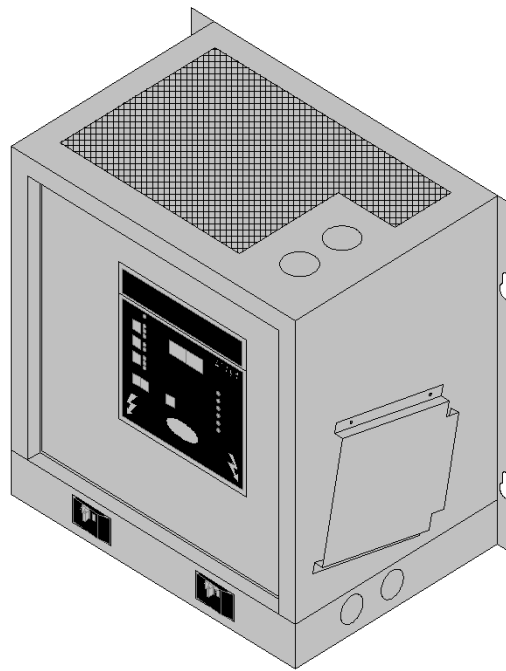

**Style-594 Enclosure**

# INSTALLING THE AT10.1

## PROCEDURE

Install four (4) 0.25in / 6.4mm anchor bolts (not supplied) rated to support the weight of the AT10.1, plus a safety factor of at least two (2) times, into the wall. Place the AT10.1 onto the anchor bolts, add appropriate mounting hardware, and tighten securely. Refer to the graphics below for AT10.1 Style-586 & Style-594 wall-mounting patterns and specifications.

## GRAPHICS - WALL-MOUNTING THE AT10.1

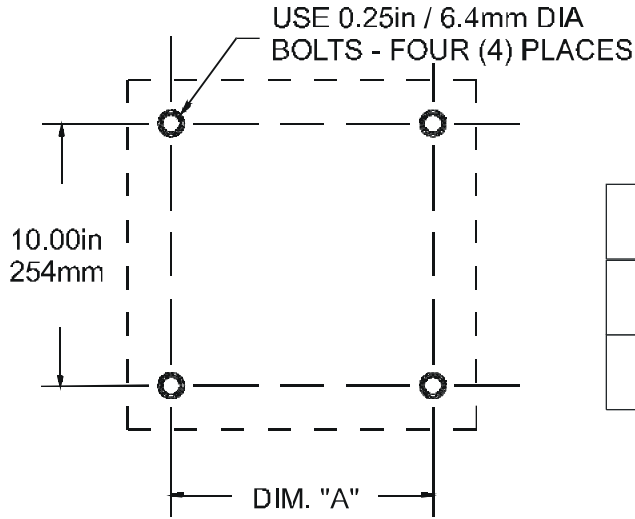

AT10.1 MOUNTING DIMENSION

ENCLOSURE	DIM. "A"
Style-586	15.00in / 381mm
Style-594	18.25in / 464mm

MOUNTING BOLT PATTERN

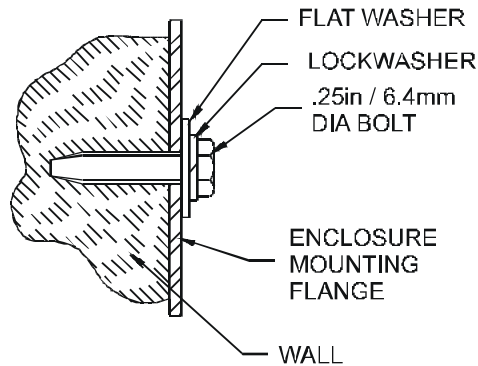

RECOMMENDED MOUNTING  
HARDWARE LOADING

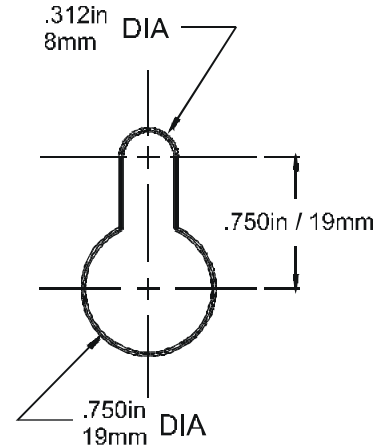

KEYHOLE SLOT USED ON  
AT10.1 MOUNTING FLANGE

# INSTALLING THE AT10.1

---

## 1.5.2. Floor-Mounting the AT10.1

To install the AT10.1 onto a horizontal surface, the standard Style-586 and Style-594 enclosures do not need to be modified, but a special floor-mounting accessory (**EI0192-00**) is required. For kit availability, see ordering information in Appendix B on page 71. The kit includes a set of mounting brackets that elevate the top of the AT10.1 approximately 47in / 1194mm above floor level, with provisions for floor anchoring. The kit also includes appropriate hardware and *Installation Instructions* ([JA0083-00](#)) for the floor-mounting procedure.

When floor-mounting the AT10.1, consider the following:

1. Locate anchor bolt holes at least 4.25in / 108mm from any wall, to allow clearance behind the mounting brackets.
2. Be conscious of planned ac input and dc output wiring to the AT10.1, selecting conduit entrances carefully. Use of the pref-fab knockouts on the sides or bottom of the enclosure will allow removal of the cabinet shroud (and internal access for servicing) without removal of the unit from the wall.
3. The location:
  - Should be free of drips and splatter. If falling particles and liquids are a problem, install a NEMA-2 type drip shield accessory (**EI0191-00**). For kit availability, see ordering information in Appendix B on page 71.
  - Should be between 0 and 122 °F / -18 and 50 °C, with relative humidity between 5% and 95% non-condensing.
  - Must be free of flammable or explosive materials.
4. Maintain at least 6in / 152mm of free air on all vented surfaces for cooling.
5. Allow 36in / 914mm front clearance for operation and maintenance.

### PROCEDURE

Install four (4) 0.25in / 6.4mm anchor bolts (not supplied) rated to support the unit weight plus a safety factor of at least two (2) times, into the floor.

Assemble the floor-mounting accessory to the anchor bolts as shown. Place the AT10.1 onto the vertical posts, add appropriate mounting hardware, and tighten.

Refer to the graphics on the opposite page for the AT10.1 Style-586 & Style-594 floor-mounting patterns and enclosure footprints.

See *Installation Instructions* ([JA0083-00](#)) for the special floor-mounting procedure.

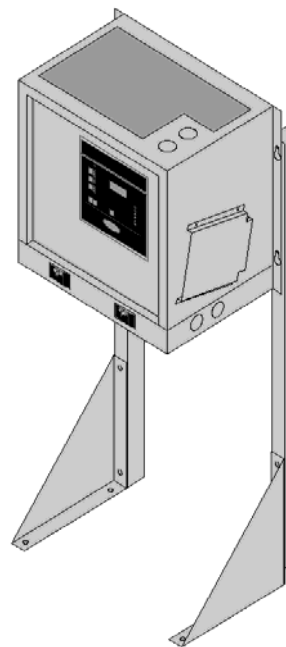

# INSTALLING THE AT10.1

## GRAPHICS - FLOOR-MOUNTING THE AT10.1

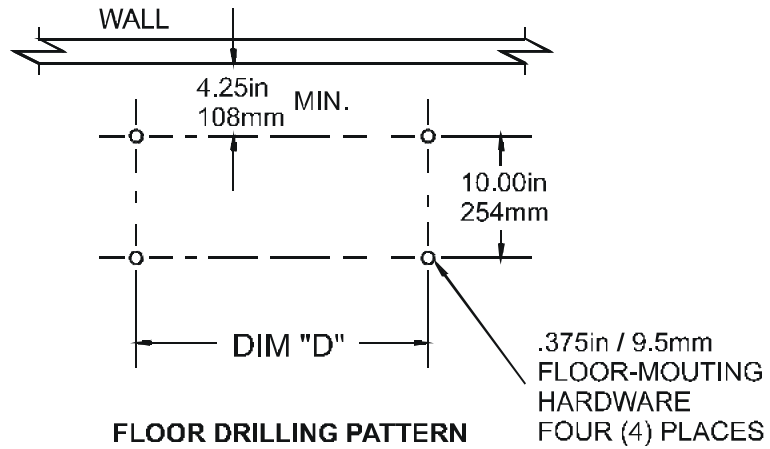
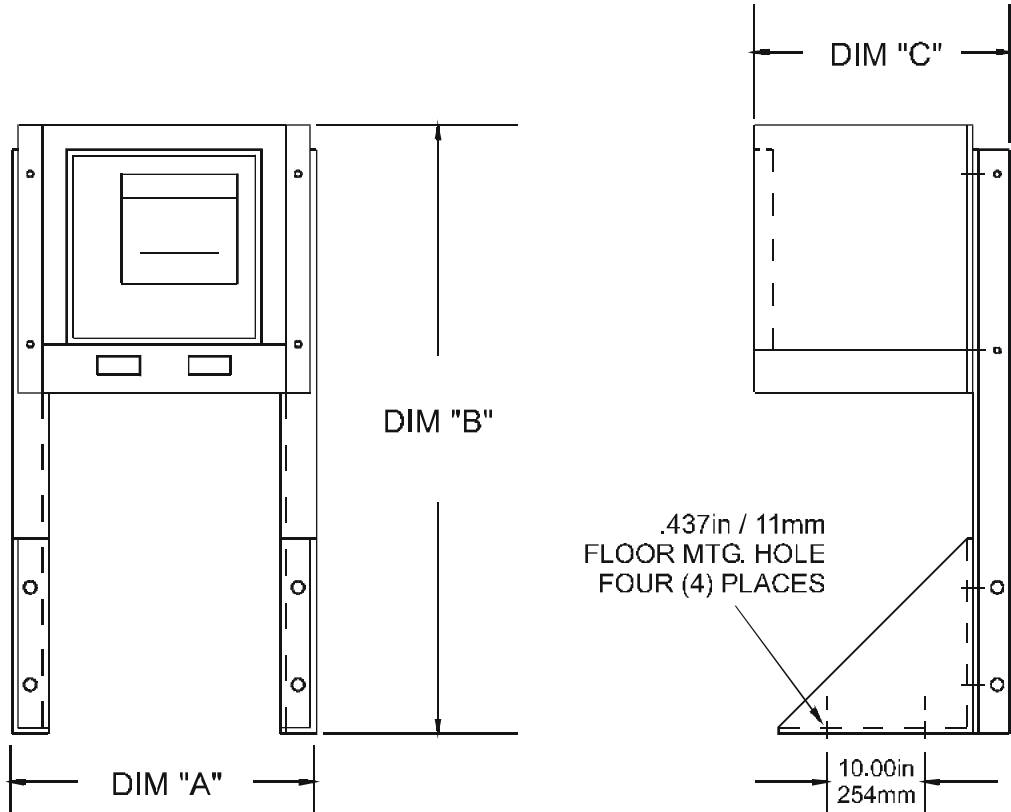

ENCLOSURE	DIMENSION (in / mm)			
	A	B	C	D
Style-586	16.50 / 419	46.63 / 1184	11.75 / 298	15.00 / 381
Style-594	19.75 / 502	47.75 / 1213	14.25 / 361	18.25 / 463

# INSTALLING THE AT10.1

---

## 1.5.3. Rack-Mounting the AT10.1

The AT10.1 can be installed into most relay racks with standard EIA hole spacing. The Style-586 and Style-594 enclosures do not need to be modified for rack mounting, but a special kit (**EI0193-00**) is required.

For kit availability see the ordering information in Appendix B on page 71. The kit includes two (2) mounting brackets, appropriate hardware, and *Installation Instructions* (**JA0091-00**) for the rack-mounting procedure. Refer to the table below for allowable combinations.

CHARGER RATING		RACK WIDTH		
Vdc	Adc	19in / 483mm	23in / 584mm	24in / 610mm
12 Vdc	all	Yes	Yes	Yes
24 Vdc	all	Yes	Yes	Yes
48 Vdc	6-12 Adc	Yes	Yes	Yes
48 Vdc	16-25 Adc	<b>No</b>	Yes	Yes
130 Vdc	6 Adc	Yes	Yes	Yes
130 Vdc	12-25 Adc	<b>No</b>	Yes	Yes

When rack-mounting the AT10.1, consider the following:

1. The rack must be strong enough to properly support the weight of the AT10.1. See the Weight Table located in Section 1.4 on page 3.
2. Be conscious of planned ac input and dc output wiring to the AT10.1, selecting conduit entrances carefully. Note the standard pre-fab conduit knockouts located on the sides, top, and bottom of the enclosures. Ensure that planned conduit is accessible after the AT10.1 is rack-mounted.
3. The location:
  - Should be free of drips and splatter. If falling particles and liquids are a problem, install a NEMA-2 type drip shield accessory (**EI0191-00**). For kit availability, see ordering information in Appendix B on page 71.
  - Should be between 0 and 122 °F / -18 and 50 °C, with relative humidity between 5% and 95% non-condensing.
  - Must be free of flammable or explosive materials.
4. Maintain at least 6in / 152mm of free air on all vented surfaces for cooling.
5. Allow at least 36in / 914mm front clearance for access to the AT10.1 for operation and maintenance.

### PROCEDURE

To rack mount the AT10.1, first install the mounting brackets into the rack using proper hardware (not supplied). Second, mount the AT10.1 onto the installed brackets, using the supplied kit hardware. Provide at least 6in / 152mm of free air above and below the AT10.1 for cooling. Refer to the graphics on the opposite page for the rack-mounting configurations.

## GRAPHICS - RACK-MOUNTING THE AT10.1

### Style-586 Enclosure

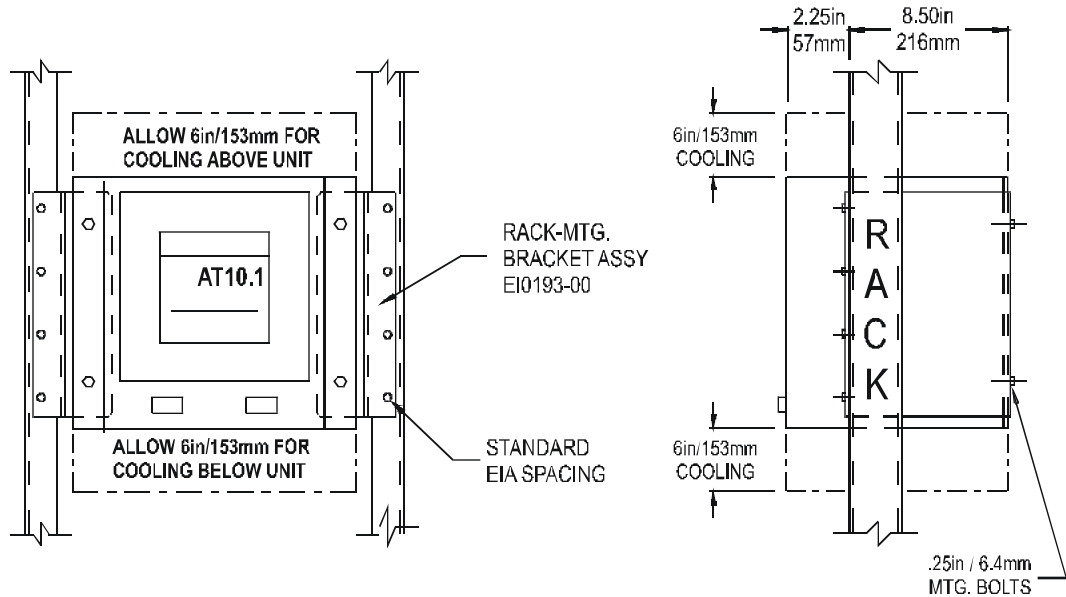

### Style-594 Enclosure

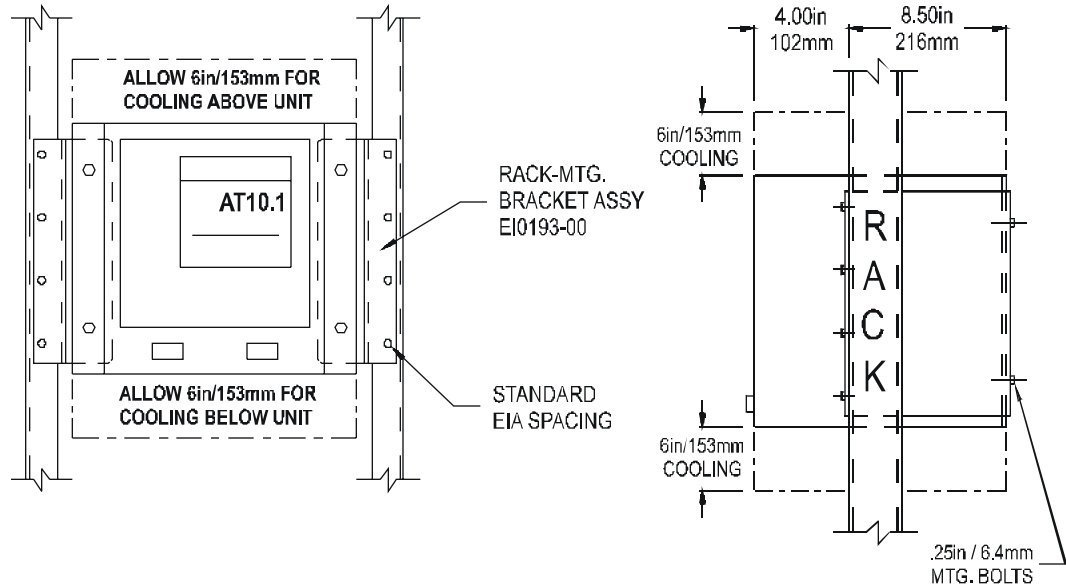

### NOTES

1. Mounting brackets and AT10.1 enclosures are installed from the front.
2. Above installations are shown without optional penthouse enclosure. If penthouse is supplied, add 7in / 178mm to top of enclosure.
3. Refer to the outline drawings for the Style-586 ([JE5023-03](#)) and Style-594 ([JE5024-03](#)) enclosures in Appendix C on pages 72 and 74.

# INSTALLING THE AT10.1

---

## 1.6. CHANGING THE TRANSFORMER TAPS

**⚠ CAUTION** Before connecting external power to the AT10.1, verify the ac input voltage listed on the data nameplate decal, and the tag attached to the ac breaker (CB1). The power isolation transformer (T1) is designed with an ac input voltage tolerance of +10% to -12%. If available site ac supply voltage does not match the AT10.1 input requirements, you may need to replace certain ac components. See Section 3.6 on page 64 for ordering replacement parts. Failure to use properly rated components may damage the AT10.1.

If your AT10.1 was supplied with one of the following ac input voltage features, the transformer *is* re-tappable:

- 120/208/240 Vac 60Hz
- 120/220/240 Vac 50/60Hz
- 380 *or* 416 Vac 50/60Hz

If the AT10.1 was supplied with the 480 Vac 60Hz ac input feature, the transformer will *only* accept the listed voltage. Do not attempt to re-tap this transformer. If the transformer is not re-tappable, and a full feature change is needed, contact your sales representative for ordering *all* voltage and current-specific ac replacement parts (T1, CB1 & VR2-VR5).

**⚠ WARNING** Before changing the transformer (T1) taps, shut down the AT10.1. Lock out ac and dc power supplies. Merely turning off (opening) the AT10.1 internal circuit breakers does *not* eliminate live voltages inside the enclosure. Allow filter capacitors (C1/C2) to bleed off. De-energize any external wiring to the AT10.1 alarm relay contacts (TB3/TB4). Verify no internal voltages are present before proceeding. Group I AT10.1s with a multi-tap (e.g. 120/208/240 Vac) input feature will list all ratings on the data nameplate decal. Inspect the wiring of the transformer (T1) inside the enclosure, and confirm it is "jumpered" for the available ac input supply voltage. If a different ac input supply is desired, identify the AT10.1 ac input feature, and whether or not the transformer (T1) is re-tappable, as listed above.

AT10.1 Group I isolation transformers feature two (2) jumpers, except those utilized in the 480 Vac option. Transformers used in the smaller (Style-586) enclosure use piggyback quick-connect terminals. Those used in the larger (Style-594) enclosure use 10-32 stud terminals.

**NOTICE** *This procedure refers **only** to AT10.1 Group I battery chargers (**rated 6-25 Adc**). Refer to a similar procedure, Section 1.6 in O&SI ([JA0102-02](#)) for Group II (**rated 30-100 Adc**) models. Otherwise, damage to the AT10.1 and site equipment may occur.*



# INSTALLING THE AT10.1

## PROCEDURE

1. Shut down the AT10.1, then see Section 3.5 for necessary steps to follow when accessing internal components within the enclosure.
2. Verify that no internal voltages are present before proceeding.
3. Refer to the images below and identify the primary "taps" (H#) on the AT10.1 Group I power isolation transformer (T1).

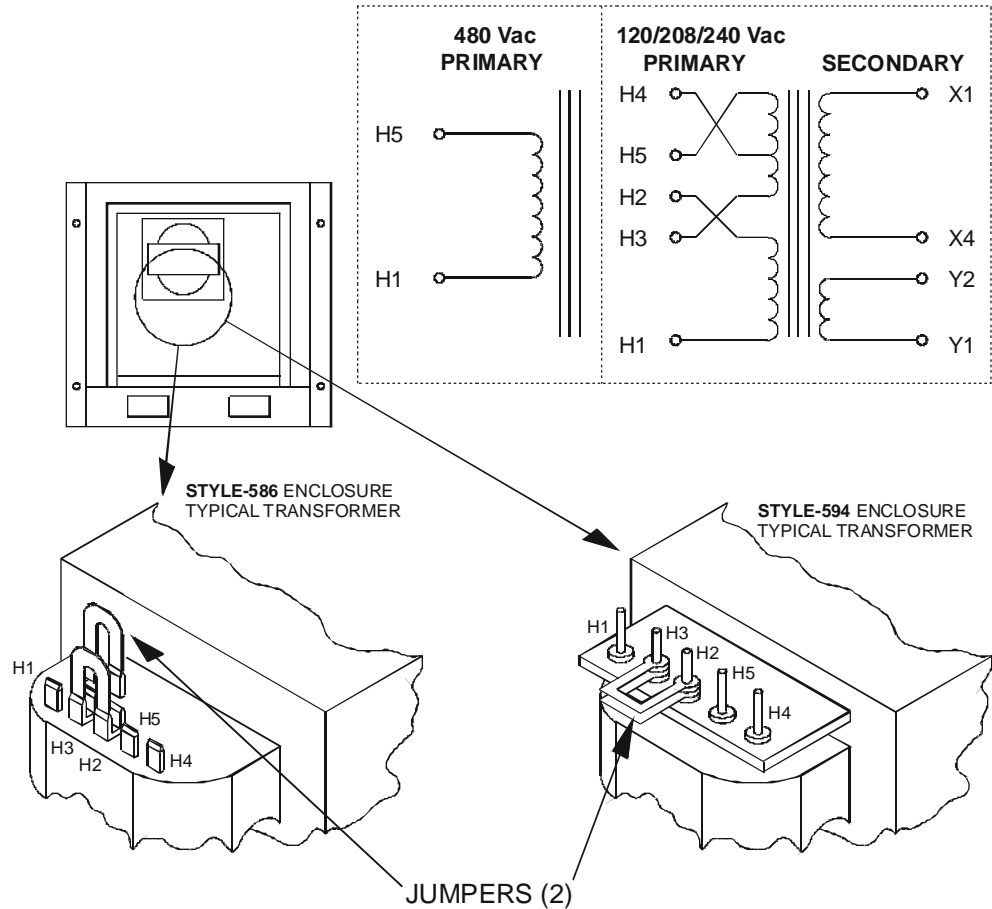

4. Inspect the transformer inside the AT10.1. Identify the five (5) primary "taps" (T1-H1, -H3, -H2, -H5 & T1-H4) arranged left-to-right.
5. 480 Vac transformers only feature T1-H1 & T1-H5, and are *not* re-tappable.
6. Identify the two (2) jumpers on the primary-side taps. Relocate as needed.

120 Vac	208 Vac	240 Vac	480 Vac
H1 to H3, H2 to H5	H2 to H4, (2) jumpers	H2 to H3, (2) jumpers	n/a

7. Always use *both* transformer jumpers as specified in the table above.
8. Confirm the ac feeder breaker, upstream from the AT10.1, is sized properly for the new ac input voltage and current.
9. For maximum ac input current values, refer to standard ([DC5016-00](#)).
10. Check your work and confirm all connections are tight.
11. Restart the AT10.1 using the procedure in Section 2.1.
12. For more information, see the schematics & wiring diagrams in Appendix C.

# INSTALLING THE AT10.1

---

## 1.7. MAKING THE AC INPUT CONNECTIONS

 **WARNING**

The AT10.1 is a commercial product, and not intended for use at any time in a residential environment, or to be powered by low-voltage public mains.

It is the responsibility of the *installer* of the AT10.1 to provide suitable ac supply wiring. Wiring must be approved for use in the country in which the AT10.1 is installed, or bear the ◀ **HAR** ▶ mark. When selecting wire sizes, consult the data nameplate decal affixed to the side panel of the AT10.1 for voltage and current requirements. For CE compliance, see Appendix G on page **Error! Bookmark not defined.** for proper grounding.

Follow these steps to supply proper ac power to the AT10.1:

1. Confirm that the AT10.1 main power transformer (T1) is properly jumpered for your ac input supply voltage. See Section 1.6 for details.
2. Use a branch circuit breaker or fused disconnect switch upstream from the AT10.1. This device should have lockout capability so that the ac input supply to the AT10.1 can be de-energized for unit maintenance. A time delay circuit breaker or slow-blow fuse is recommended.
3. Size the branch circuit breaker or fused disconnect switch for the maximum ac input current of the AT10.1. This rating is listed on the left-hand side of the AT10.1 data nameplate. For a comprehensive list of these maximum ac input values, access standard ([DC5016-00](#)).
4. Size ac input wiring per the National Electric Code (NEC) and local codes for the trip rating of the branch circuit breaker or fused disconnect switch.
5. Do not run external ac input power wiring through the same conduit of the AT10.1 enclosure as external dc output power wiring.
6. All site requirements of your facility take precedence over these instructions.

### PROCEDURE

1. Remove the Plexiglas safety shield.
2. Run the ac input supply wiring into the AT10.1, ending at terminals TB1-L1, TB1-L2, and TB1-GND on the I/O panel board.
3. The AT10.1 features three (3) CU-AL compression lugs on the ac input terminals, which accept #14 - 6 AWG wire. Strip 0.50in / 13mm from the insulation of the incoming ac input supply wiring.
4. Connect the wires to the appropriate ac lugs as shown on the next page.
5. Using a flat-head screwdriver, securely tighten the compression screws on the ac lugs to 35-45 in-lb / 4.0-5.1 Nm.
6. Check all connections and reinstall the Plexiglas safety shield.

## MAKING THE AC INPUT CONNECTIONS - GRAPHICS

REPLACE SAFETY COVER  
AFTER CONNECTIONS ARE MADE

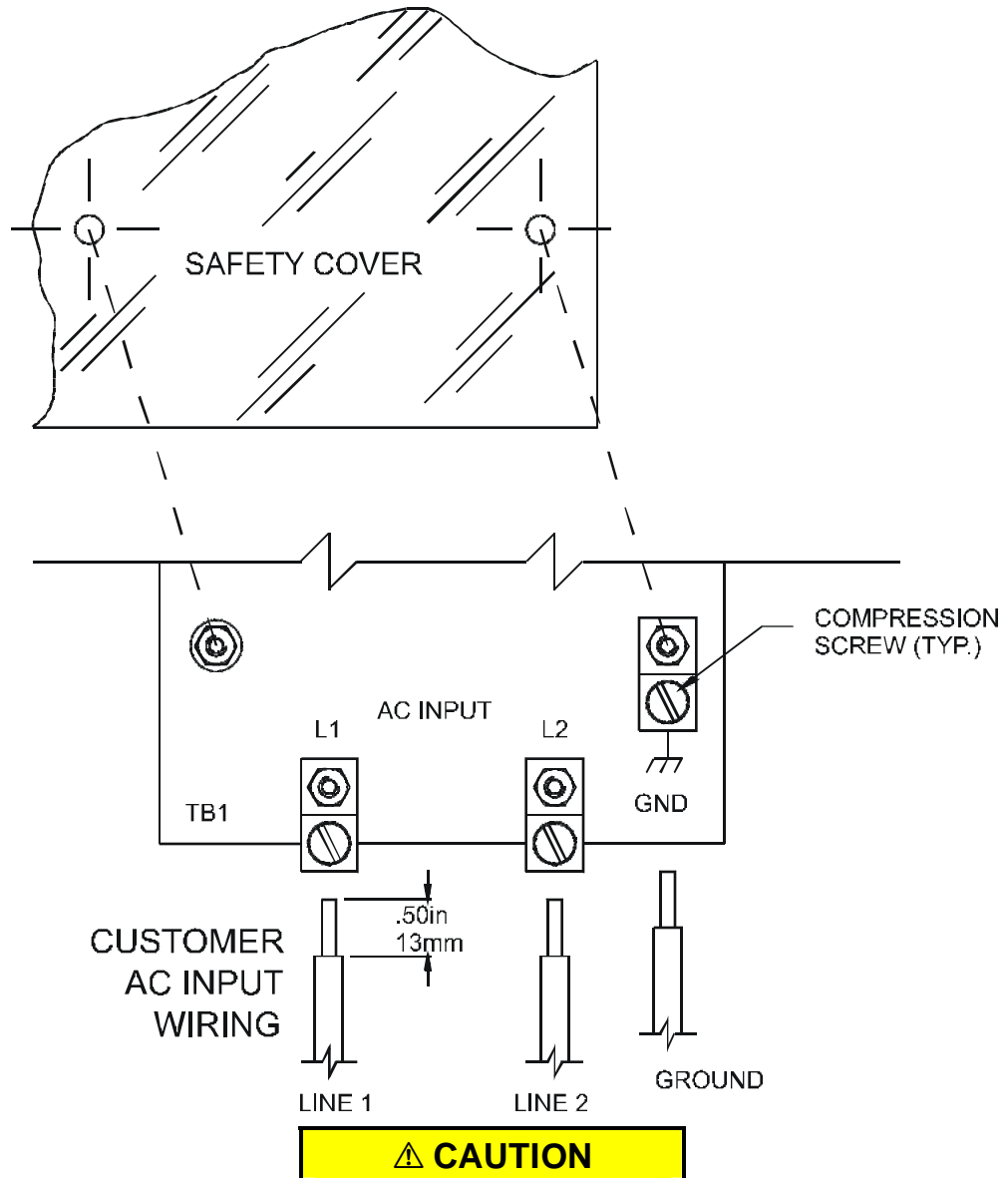

### NOTES

1. The drawing above does not show other components mounted to the I/O panel. Be careful not to disconnect any other component leads.
2. Conduit must be properly grounded, and in compliance with the national wiring rules of the country where installed. See Appendix G for details.
3. Use copper or aluminum conductors only.
4. On 120 Vac input, connect the neutral leg to the terminal L2.

# INSTALLING THE AT10.1

---

## 1.8. MAKING THE DC OUTPUT CONNECTIONS

It is the responsibility of the *installer* of the AT10.1 to provide suitable dc output, battery, and dc load wiring. Follow these steps to connect the battery to the AT10.1:

1. Size the dc wiring to minimize voltage drop. The acceptable wire size depends on your installation. As a guideline, the voltage drop should not exceed 1% of nominal output voltage at full current. Refer to the table below to determine the voltage drops for various wire sizes, currents and distances.

### WIRE SIZING CHART

VOLTAGE DROP PER 100ft / 30.5m OF WIRE (for copper at 68 °F / 20 °C)

WIRE SIZE (AWG)	DC CURRENT (Amperes)				
	6	12	16	20	25
#16	2.5V	5.0V	6.7V	8.2V	10.5V
#14	1.6V	3.2V	4.2V	5.3V	6.6V
#12	1.0V	2.0V	2.6V	3.3V	4.2V
#10	0.63V	1.3V	1.7V	2.1V	2.6V
#8	0.40V	0.80V	1.1V	1.3V	1.7V
#6	0.25V	0.50V	0.66V	0.83V	1.1V
#4	0.16V	0.32V	0.42V	0.52V	0.65V

*EXAMPLE: 100ft / 30.5m of #8 AWG wire at 16A has a 1.1V drop.*

2. The AT10.1 is factory wired to regulate output voltage at the output terminals. If the total voltage drop is greater than 1% (e.g., 1.3V for a 130 Vdc system), remote sense wiring is recommended, see Section 1.9.
3. Do not run external ac and dc power wiring, feeding the AT10.1, through the same conduit.
4. All specific requirements of your facility take precedence over these instructions.

### PROCEDURE

1. Use a dc disconnect switch or circuit breaker between the AT10.1 and dc bus. This device should have lockout capability to allow the AT10.1 to be disconnected from the dc bus for maintenance.
2. Remove the Plexiglas safety shield.
3. Run the dc wiring to terminals TB1(+) and TB1(-) on the I/O panel board in the enclosure. Compression lugs, accepting wire sizes #14-6 AWG, are supplied for your convenience.
4. Strip the insulation 0.50in / 12.7mm on the incoming wires. Connect the wires to the appropriate dc lugs as shown on the next page.
5. Using a flat-head screwdriver, securely tighten the compression screws on the lugs to 35-45 in-lb / 4.0-5.1 Nm.
6. Reinstall the safety shield after you have made and checked all connections.

## MAKING THE DC OUTPUT CONNECTIONS - GRAPHICS

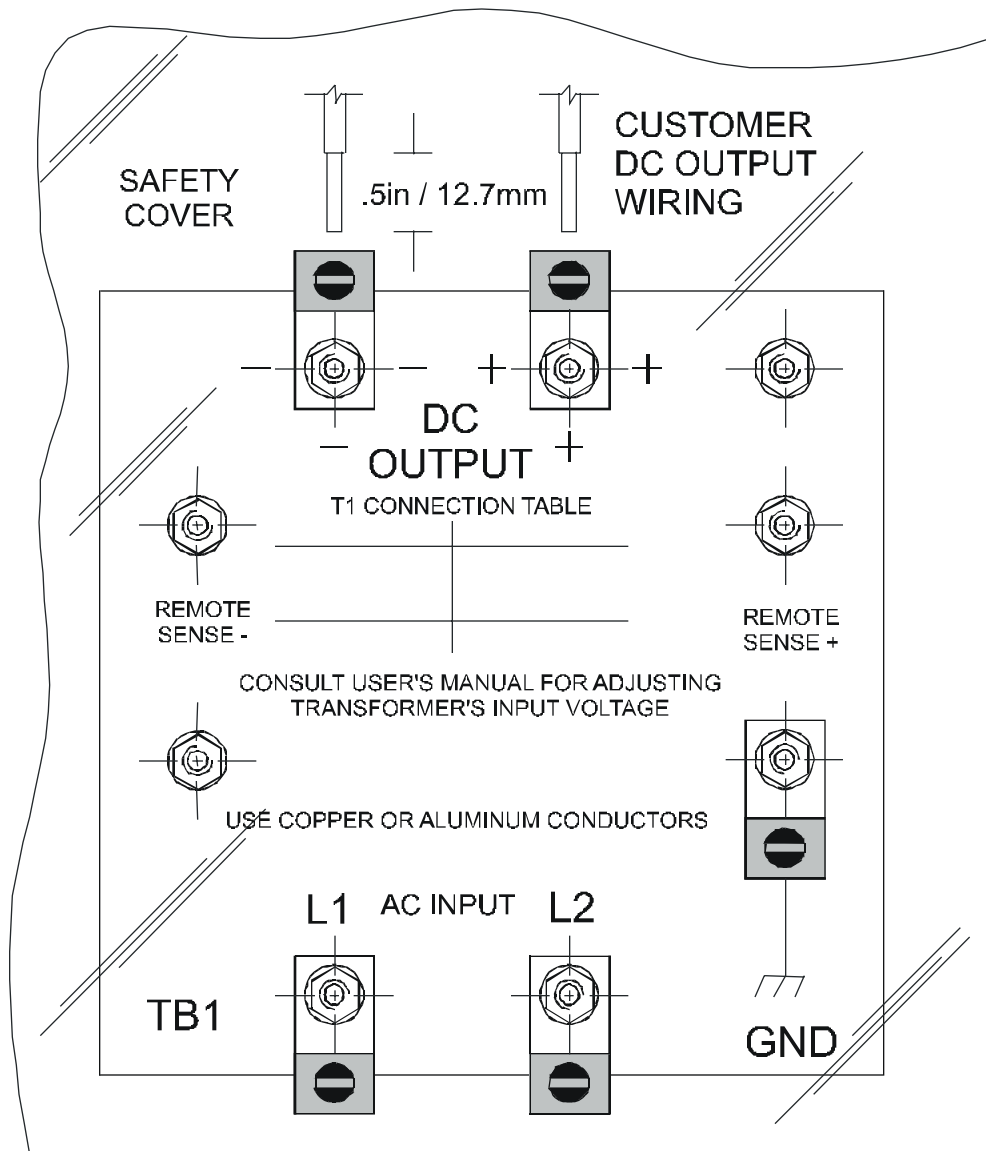

**⚠ CAUTION**

### NOTES

1. The drawing above does not show other components mounted to the I/O panel. Be careful not to disconnect any other component leads.
2. Always use a proper ground.
3. Use copper or aluminum conductors only.

# INSTALLING THE AT10.1

## 1.9. WIRING THE AT10.1 FOR REMOTE SENSING

You can wire the AT10.1 to regulate the output voltage at the battery terminals, instead of at the charger output terminals (TB1+/-). Remote sensing provides the following:

1. Compensates for voltage drop in the dc wiring between the AT10.1 and the battery.
2. Directly monitors the battery or dc bus voltage. The front panel meter displays the actual voltage on the battery or dc bus.

### SCHEMATIC

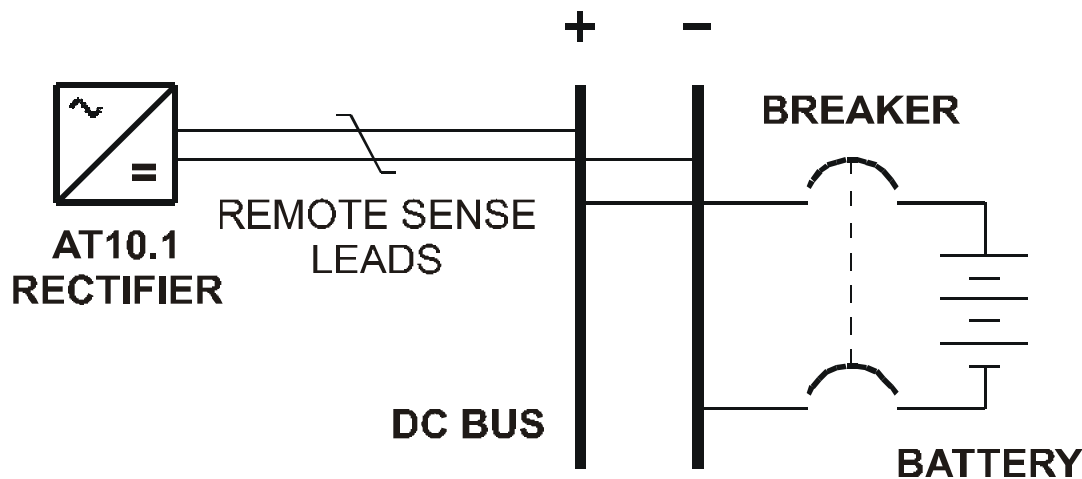

You wire the AT10.1 for remote sensing by installing twisted pair cabling from the AT10.1 remote sense terminals to the battery terminals. The AT10.1 control circuitry then measures the dc voltage at the battery terminals, and controls the output of the charger to maintain the battery voltage at the desired float or equalize voltage.

#### NOTICE

*If the remote sense wiring fails, the AT10.1 detects the fault, and displays **E 06** on the front panel meter. See Section 3.2 for details.*

#### CAUTION

*The AT10.1 cannot protect against short circuits in the remote sense wiring. You should install a 1.0A fuse at the battery or dc bus end of the remote sense cable.*

### PROCEDURE

1. De-energize and lock out all ac and dc voltages within the AT10.1 enclosure. Check with a voltmeter.
2. Remove safety shield.
3. Remove the two (2) dc output CU-AL compression lugs.

## INSTALLING THE AT10.1

4. Move lugged end of R14 (with wire # **20**) from TB1(-) to REM SENSE(-).
5. Move wire # **21** from TB1(+) to REM SENSE (+).
6. Connect user-supplied external remote sense leads from the battery or dc bus to the remote sense terminals on the I/O panel.

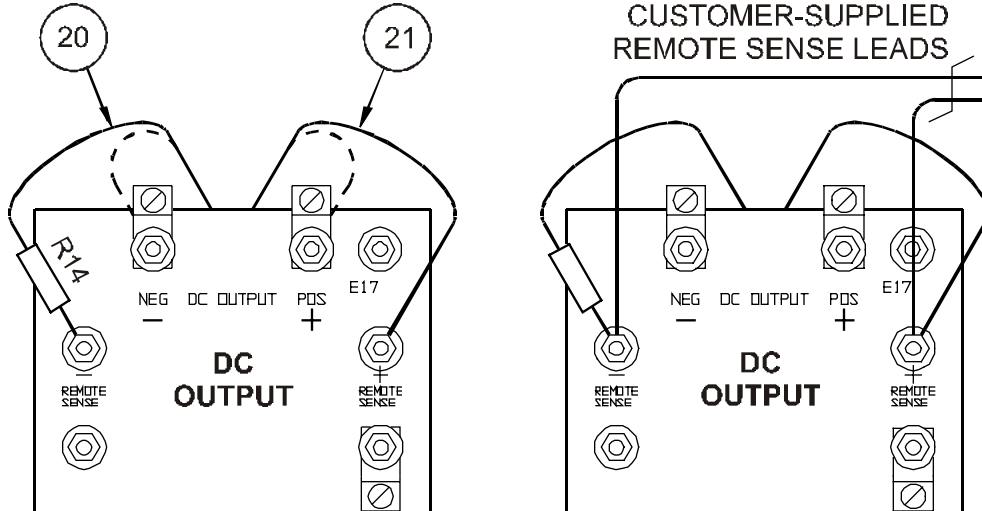

7. Replace the two (2) dc output CU-AL compression lugs and tighten all hardware.
8. Check your work thoroughly. Replace the safety shield before re-energizing the AT10.1.
9. Restart the AT10.1 according to the instructions in Section 2.1.

### NOTES

1. Use #16 AWG twisted pair wire.
2. Maximum current is 150 mA.
3. Run leads in their own conduit.
4. Fuse the wiring at the battery or dc bus.

### DISABLING REMOTE SENSE

If you ever need to disable remote sense, follow the steps below:

1. De-energize and lock out all ac and dc voltages to the AT10.1.
2. Check with a voltmeter.
3. Disconnect the remote sense wires from the battery or dc bus **first**.
4. Remove the remote sense leads from the remote sense (+) and (-) terminals on the I/O panel (TB1) **second**.
5. Insulate each lead separately, coil up the wires, and leave them in the bottom of the AT10.1, in case you want to wire for remote sense in the future.
6. Reconnect the lugged end of R14 (with wire # **20**) to TB1(-).
7. Reconnect wire # **21** to TB1(+).
8. Restart the AT10.1 according to the instructions in Section 2.1.

# INSTALLING THE AT10.1

## 1.10. WIRING TO THE REMOTE ALARM CONTACTS

### *Built-in Summary "Common" Alarm Relay (standard)*

The AT10.1 Main Control PC Board (A1) is equipped with a "common" Summary Alarm relay. This relay contact transfers when any one or more of the standard AT10.1 alarms exist.

See Section 2.2.1 on page 26 for a list of these alarms and status codes. One form-C alarm contacts are provided, and accessible via terminal block (TB3), as shown in the figure to the right.

Follow the procedure below to wire a remote annunciator to this contact.

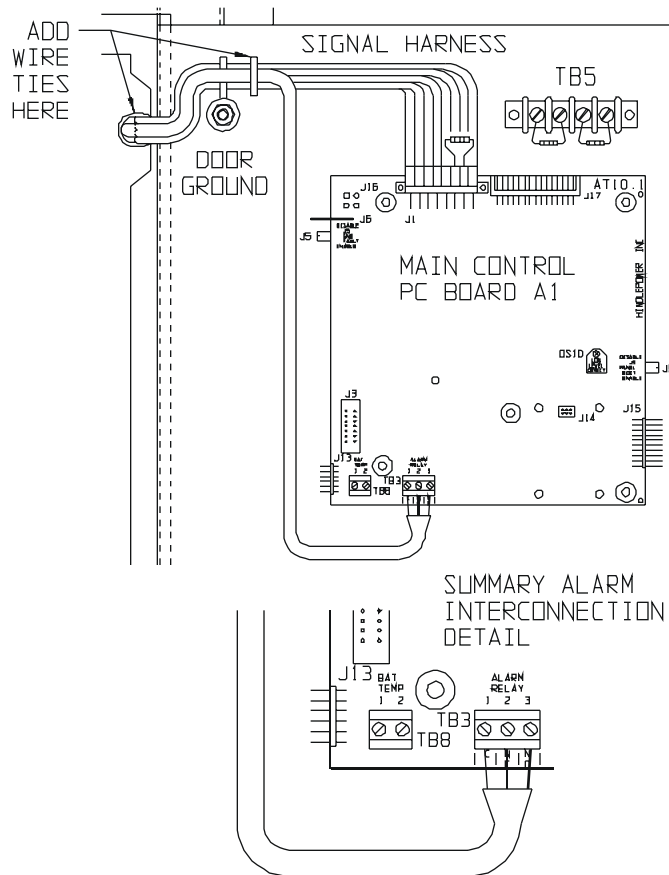

### PROCEDURE

1. Allow 30in / 762mm of wire inside the enclosure. Excess will be trimmed.
2. Route annunciator wires to the AT10.1 front panel door by following the existing harness through the door hinge as shown. Use two (2) wire ties and allow a 4-6in / 102-153mm loop for the hinge.
3. Trim wires to the proper length for connecting to TB3. Strip 0.25in / 6.4mm of insulation from the wires.
4. Make the connections at TB3, and securely tighten compression screws.

### NOTES

1. Alarm contacts are rated at 0.5A / 125 Vac or Vdc.
2. Summary Alarm relay terminal block (TB3) is compression type, accepting wire sizes #22-14 AWG.
3. Terminals are labeled in non-alarm condition.
4. If user alarm contacts (TB3 and/or TB4A/B) are to drive inductive **dc** loads (e.g. a larger dc relay) an external protective diode must be applied at the dc relay to avoid equipment damage. See *Application Note* ([JD5011-00](#)).



# INSTALLING THE AT10.1

## *Auxiliary Alarm Relay PC Board (optional)*

The optional Auxiliary Alarm Relay PC Board (A5), mounted inside the separate top enclosure (penthouse), provides two (2) form-C contacts (TB4-1 through TB4-36) for each of the following individual alarms:

- High DC Voltage
- Low DC Voltage
- DC Output Failure
- AC Input Failure
- Ground Fault Detection (positive or negative)
- Summary (common) Alarm

Alarm contacts (TB4A/B), marked in non-alarm condition, are as follows:

HVDC			LVDC			DC OUT FAILURE			AC FAIL			GROUND DETECT			SUMMARY																				
C, NC, NO	C, NC, NO	C, NC, NO	C, NC, NO	C, NC, NO	C, NC, NO	C, NC, NO	C, NC, NO	C, NC, NO	C, NC, NO	C, NC, NO	C, NC, NO	C, NC, NO	C, NC, NO	C, NC, NO	C, NC, NO	C, NC, NO																			
1	2	3	4	5	6	7	8	9	10	11	12	13	14	15	16	17	18	19	20	21	22	23	24	25	26	27	28	29	30	31	32	33	34	35	36

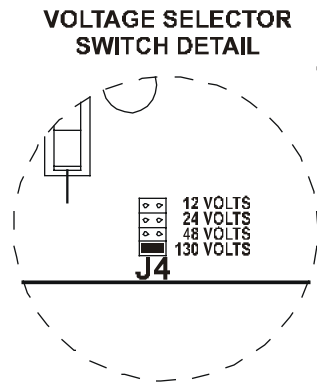

TB4

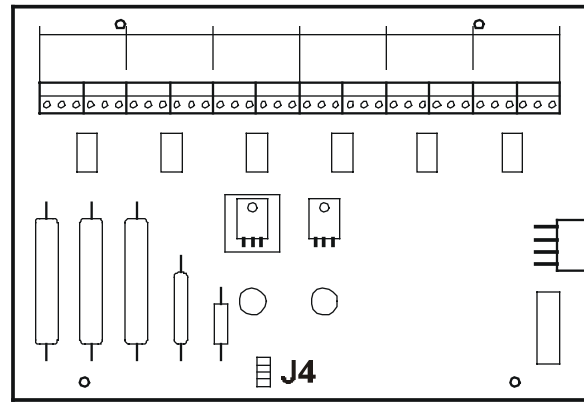

## PROCEDURE

1. De-energize and lock out all ac and dc voltages to the AT10.1.
2. Allow internal voltages to dissipate, then check with a voltmeter.
3. Remove the top panel from the penthouse enclosure (on top of chassis).
4. Route your remote annunciator wiring into the penthouse enclosure through one of the unused knockouts on the side of the enclosure.
5. As shown in the figure above, connect the wiring (use #22-14 AWG) to the appropriate terminals of TB4 on the Auxiliary Alarm Relay PC Board (A5).
6. Strip each wire 0.25in / 6.4mm, and securely tighten the terminal screws.
7. Replace the top panel on the penthouse enclosure and restart the AT10.1.

## NOTES

1. Alarm contacts are rated at 0.5A / 125 Vac or Vdc.
2. Terminal block (TB4) is compression type, accepting #22-14 AWG wire.
3. Terminals are labeled in non-alarm condition.
4. For a detailed view of the optional Auxiliary Alarm Relay PC Board (A5), refer to drawing ([JE5030-19](#)) listed in Appenix C on page 78.

# INSTALLING THE AT10.1

---

## 1.11. INSTALLING THE TEMPCO PROBE ASSEMBLY (OPTIONAL)

The temperature compensation (or TempCo) probe contains a temperature-dependent resistor in an epoxy module that you install near your battery. There are three (3) steps in installing the assembly:

1. Mounting the probe assembly near the battery.
2. Installing an interconnection cable from the probe assembly to the AT10.1.
3. Wiring the **charger end** of the cable to a terminal block on the AT10.1.

The actual temperature compensation probe (A10), or puck, is the same for all battery types and all output voltages of the AT10.1. The accessory part numbers differ depending on cable length ordered. See the tables in Appendix B on page 71 for ordering information. Each kit contains detailed *Installation Instructions* ([JA5015-00](#)), and a separate *Application Note* ([JD5003-00](#)) for further user details. The main elements of the installation are outlined below.

### WARNING

*High voltages appear at several points inside the AT10.1. Use extreme caution when working inside the enclosure. Do not attempt to work inside the AT10.1 unless you are a qualified technician or electrician. Disconnect and lock out all power from the AT10.1 before starting to remove or replace any components. Turn the ac power off at the distribution panel upstream from the charger. Disconnect the battery from the AT10.1 output terminals TBI(+/-).*

### PROCEDURE

1. De-energize and lock out all ac and dc voltage sources to the AT10.1, and check with a voltmeter before proceeding.
2. Mount the probe on a clean, dry surface, as close to the battery as possible, such as the battery rack. **DO NOT** mount the probe:
  - on the battery itself
  - on unpainted wood, or bare galvanized metal
  - on plastic surfaces
3. To apply the probe, clean the mounting surface with isopropyl alcohol, and allow to dry thoroughly. Remove the protective backing from the double-faced adhesive tape on the probe, and securely press it onto the surface.
4. Install the cable supplied with the temperature compensation probe kit:
  - Start at the AT10.1. The end of the cable with two (2) stripped wires and a quick-connect terminal will be installed inside the AT10.1.
  - Leave 30in / 762mm of cable inside the enclosure, and route the other end to the probe at the battery.

## INSTALLING THE AT10.1

- Run the cable through a conduit if possible, but not through a conduit containing any power wiring.
- Route the other end to the probe at the battery and coil up excess cable.

### NOTICE

If the standard (25ft / 7.6m) cable is not long enough, longer cable assemblies are available in lengths of 50, 100 & 200ft / 15.2, 30.5 & 61.0m. See Appendix B on page 71 for ordering information.

- Make sure all wiring conforms to NEC, local, and site requirements.
5. Attach the interconnection cable to the AT10.1 as shown in the figure below:

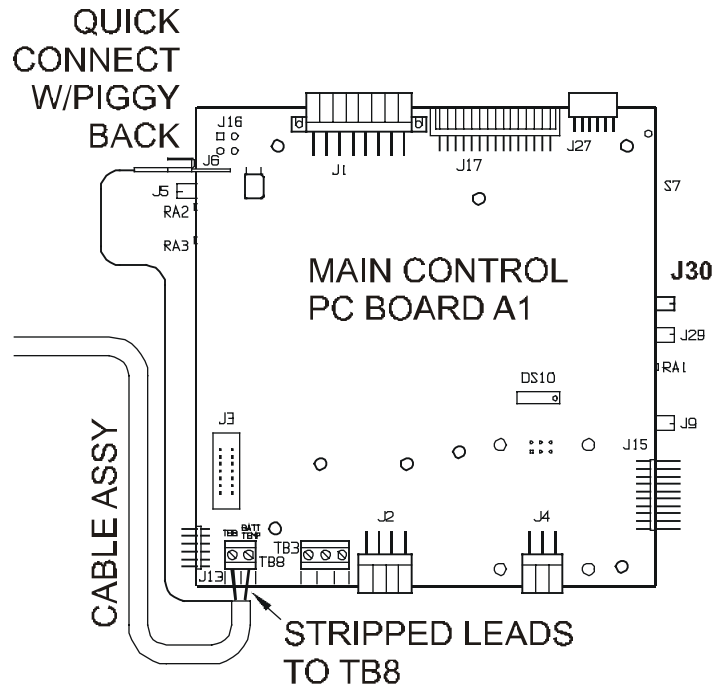

- Route the cable within the AT10.1 enclosure so it runs with the wire harness to the back of the front panel, and easily reaches the Main Control PC Board (A1).
  - At the Main Control PC Board (A1), insert one of the bare wires from the cable into each terminal of TB8. Polarity is not vital.
  - Unplug the harness ground wire # 30 from terminal J6 on the left edge of the Main Control PC Board (A1). Plug the connector at the end of the nylon-shielded wire of the cable assembly onto J6. Reconnect the ground wire # 30 from the system harness onto the piggy-back connector featured at the end of the nylon-shielded wire.
  - Using plastic wire ties, fasten the interconnection cable loosely to the existing wire harness. Make sure that the cable conforms to the service loop at the hinge end of the door.
6. At the battery, connect the quick-connect terminals to the temperature compensation probe. Polarity is not vital. Coil up any excess wire and tape or tie it together to prevent damage.
7. Set jumper (J30) on the Main Control PC Board (A1) to positions 2-3 to use *compensated* voltages, or to positions 1-2 to use *uncompensated* voltages.

## INSTALLING THE AT10.1

---

8. Check your work. Confirm that:
  - All connections are secure.
  - The shield is connected to ground at the *charger end only* (A1-J6).
  - The cable is connected to the 2-position terminal block (TB8) on the Main Control PC Board (A1). Other terminal blocks may look similar.
9. Restart the AT10.1 using the startup procedure in Section 2.1. During startup, the AT10.1 displays **Pb** on the front panel meter, indicating that the temperature compensation is set up for lead-acid battery types. While this is being displayed, you can press any front panel key to change the display to read **nicd**, to change the temperature compensation setup for nickel-cadmium batteries. The choice you make is saved internally, and will be used again by the AT10.1 the next time it starts.
10. Adjust the output float and equalize voltages to the battery manufacturer's recommended values, using the AT10.1 front panel meter, as described in Section 2.3.2.

### NOTICE

*If the temperature compensation probe, or the probe wiring, is damaged and becomes an open circuit, the AT10.1 detects the damage and displays **E 08** on the front panel meter. The AT10.1 then reverts to normal non-temperature-compensated operation until the probe or wiring is repaired. Once the probe is repaired, you must restart the AT10.1 to activate the probe, as described in Section 2.1.*

#### *Using temperature compensation*

When an electric storage battery is being charged, the terminal voltage of the battery changes a small amount whenever the battery temperature changes. As the battery temperature increases, its terminal voltage decreases. When a constant output voltage float type rectifier charges a battery, float current increases when the temperature increases. This results in overcharging the battery, which can result in damage to the materials, or at least the need for more frequent maintenance.

When the AT10.1 is equipped with a temperature compensation probe, it is able to adjust the output voltage applied to the battery to keep the float current constant, thereby avoiding overcharging. The probe senses the ambient temperature at the battery, and adjusts the output float/equalize voltages to compensate for variations in temperature. If the ambient temperature increases, the AT10.1 output voltage decreases.

If you are experiencing any inconsistencies in the AT10.1 when the temperature compensation probe is utilized, temporarily disconnect the probe and refer to *Application Note* ([JD5003-00](#)) for further details.

# INSTALLING THE AT10.1

Note the following:

- You should set the Float and Equalize voltages to the values recommended by your battery manufacturer for 77 °F / 25 °C.
- When you enter the **Edit Mode** to adjust the Float or Equalize voltage (see Section 2.3.2), the front panel meter displays the 77 °F / 25 °C value for the Float or Equalize voltage, even if the battery is warmer or cooler than 77 °F / 25 °C.
- The actual output voltage of the AT10.1 may be different from the value displayed on the front panel meter, if the battery is warmer or cooler than 77 °F / 25 °C.
- Use a digital meter to measure the actual output voltage of the AT10.1. If you know the temperature at the temperature compensation probe, you can use the graph below to determine that the output voltage is correct.
- If the battery temperature goes below 32 °F / 0 °C, there will be no further increase in AT10.1 output voltage. Likewise, if the battery temperature goes above 122 °F / 50 °C, there is no further decrease in output voltage.

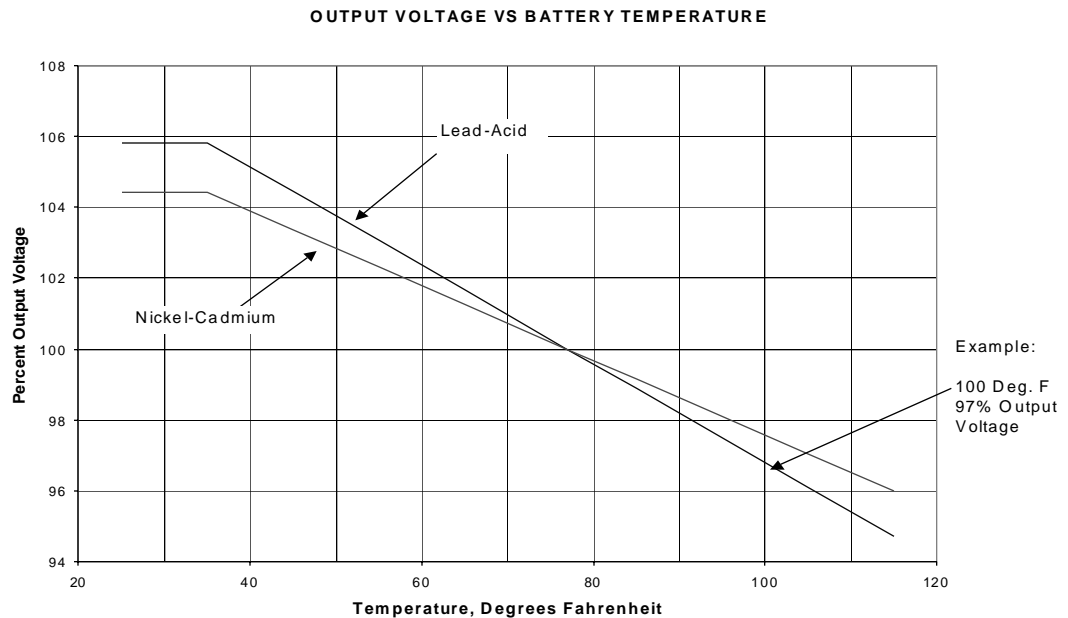

**EXAMPLE:** Suppose you have a lead-acid battery whose temperature is 100 °F / 37.8 °C. As shown on the graph, the output voltage should be approximately 97% of the 77 °F voltage. If the float voltage is set on the front panel to 132 Vdc, the actual output voltage will be:

$$132 \times 0.97 = 128 \text{ Vdc}$$

## 1.12. INSTALLING FOR REMOTE COMMUNICATION (OPTIONAL)

Refer to separate *Operating Instructions* ([JA0102-04](#)).

## 1.13. INSTALLING FOR FORCED LOAD SHARING (OPTIONAL)

Refer to Appendix F on page 90 or *Operating Instructions* ([JA5054-00](#)).

# OPERATING THE AT10.1

---

## 2. OPERATING THE AT10.1 BATTERY CHARGER

### 2.1. STARTING THE AT10.1

#### 2.1.1. Understanding the startup sequence

The AT10.1 is set up at the factory to work with most common batteries and loads without further adjustment. When you start the AT10.1 for the first time, the factory settings (float voltage, equalize voltage, etc.) control the operation of the charger. You can change the settings after you start the AT10.1. The **FACTORY SETTINGS** are listed in table on page 25. The AT10.1 startup routine takes about 5 seconds. The microprocessor that controls the AT10.1 initializes the charger by reading the settings that are stored internally. The control circuitry then "soft starts" the AT10.1, and the dc output voltage and current increase gradually to the rated value.

#### 2.1.2. Checking the installation

Confirm that you have followed the installation instructions carefully. Check the ac input supply voltage and the battery voltage, and make sure they match the information on the AT10.1 nameplate. *Verify that the jumpers on the main transformer (T1) are correct for your ac supply voltage.* Open the front panel, and check the battery polarity at the dc output terminals TB1(+/-).

#### 2.1.3. Starting the AT10.1

When you are sure that all connections to the AT10.1 are properly made, follow these steps to start up the AT10.1:

- Turn on (close) the dc output circuit breaker (CB2) *first*.
- The digital dc meter indicates battery voltage only. If the meter display does not light, **do not proceed**. Turn off (open) the dc breaker (CB2).
- Check all connections and the battery polarity again. Also check the battery voltage. It must be above 50% of nominal voltage to turn on the display. If you cannot find the problem, refer to the *Troubleshooting Procedure* in Section 3.1 on page 44.

#### Using the Digital Meter

When you first start the AT10.1, the meter display alternates between dc output voltage and dc output current.

Each reading is held for 2 seconds. Lights to the left of the display indicate whether the meter is displaying voltage or current.

If you want to "freeze" the meter to display only voltage, press the **METER MODE** key on the front panel. To freeze the meter to display only current, press the key again. Press the key twice more to revert to the alternating display.

#### NOTICE

*If you attempt to turn on the dc circuit breaker (CB2) with the battery connected in reverse polarity, the breaker will immediately trip. Do not try to close the dc breaker again, since this may damage the AT10.1. Correct the battery polarity before proceeding.*

## OPERATING THE AT10.1

- If you have an optional temperature compensation probe installed, the front panel displays **Pb** during startup, indicating that temperature compensation is set up for lead-acid battery types. While this is being displayed, you can press any front panel key to change the display to read **nicd**, to change the temperature compensation setup for nickel-cadmium batteries. The choice you make is saved internally, and will be used again by the AT10.1 then next time it starts.
- Turn on the front panel ac circuit breaker. The digital meter displays the output voltage and current. See *Using the Digital Meter* on page 24. You should hear a soft hum from the AT10.1 as the output current increases.

### NOTICE

*If you have a filtered model of the AT10.1, and you turn on the ac breaker (CB1) first, before the dc breaker (CB2), there is a possibility that CB2 will trip when you try to turn it on. This is caused by the dc filter capacitors (C1/C2) discharging into the battery. To get around this problem, turn off the ac breaker and restart the AT10.1 by turning on the **dc breaker first**.*

- The green **FLOAT** indicator lights. Press the **CHRG MODE** key on the front instrument panel. The **FLOAT** indicator goes off, and the yellow **EQLZ** indicator lights. Press the **CHRG MODE** key again to return the AT10.1 to the float mode.

The table below lists the normal factory settings for float and equalize voltages, equalize time, Current Limit setting, and alarm settings. If your purchase order specified other float or equalize voltage settings, a tag attached to the front panel of the AT10.1 lists the actual voltage settings.

### FACTORY SETTINGS FOR ALL PARAMETERS

Parameter	Nominal Vdc			
	12	24	48	130
Float Voltage	13	26	52	131
Equalize Voltage	14	28	56	139
HVDC Alarm	14.4	28.8	57.6	144
LVDC Alarm	12	24	48	120
Equalize Time	24 hours			
Equalize Method	Manual Timer			
Current Limit	110% of nominal output current			
HVDC Shutdown	Disabled			

# OPERATING THE AT10.1

---

## 2.2. USING THE AT10.1 FRONT PANEL FEATURES

### 2.2.1. If the meter displays an error or status message

The AT10.1 microprocessor control circuitry performs diagnostic checks of the battery charger during system start-up, then continuously during operation. If it detects a failure (**E ##**) or special status (**A ##**), an intermittent code will appear on the front instrument panel, displayed between dc output values.

Code	Explanation	Summary
E 01	rating resistor R2 open or defective	Yes
E 02	short circuit on dc output	Yes
E 03	high dc voltage shutdown occurrence	Yes
E 04	internal memory failure	Yes
E 06	voltage sense failure (internal / external / remote)	Yes
E 07	dc breaker open, or dc output wiring defective	Yes
E 08	remote TempCo probe defective	Yes
E 10	open internal feedback loop	Yes
E 12	internal over-temp circuit defective	Yes
E 13	rectifier over-temperature occurrence	Yes
E 14	forced load sharing not working properly	No
E 15	battery open	Yes
E 16	remote shutdown	Yes
A 01	manual equalize enabled for more than 24 hours	Yes
A 02	equalize mode inhibited	No
A 04	voltmeter calibration inhibited w/TempCo active	No
A 05	dc output at Current Limit setting	No

See Section 3.2 on page 45 for a full explanation of each code. Codes **E 05**, **E 09**, **E 11**, and **A 03** are not used. Other codes are as follows.

Pb / nicd	battery type for active temperature compensation
LS-P / LS-S	forced load sharing status (primary / secondary)
AStL	latching alarm reset
test	battery open alarm test

### 2.2.2. Selecting the meter mode

- Press the **METER MODE** key to change the meter display mode. The digital meter has four (4) operating modes:
  1. Alternating between output voltage and output current. When the AT10.1 is in a timed equalize mode, the meter alternates between output voltage, output current, and equalize hours remaining.
  2. Displaying output voltage only. The **DC Volts** indicator lights.
  3. Displaying output current only. The **DC Amperes** indicator lights.
  4. Displaying equalize hours remaining only. The **EQLZ HRS REMAINING** indicator lights. If the AT10.1 is not in timed equalize mode, the meter displays the full programmed equalize time.



- When the AT10.1 starts initially, the meter alternates, displaying output voltage and output current. The **DC VOLTS** and **DC AMPERES** indicators light alternately to indicate what is being displayed.

### 2.2.3. Selecting the Float or Equalize mode

The AT10.1 has two (2) output voltage settings, Float and Equalize. Use the Float mode for all normal battery charging and to operate your dc system. Use the Equalize mode if it is necessary to balance the level of charge among the cells of the battery. Consult your battery data sheets for information on equalize-charging your battery.

- Press the **CHRG MODE** key to change to Equalize mode.
- Press the **CHRG MODE** key at any time to change back to Float mode.

If the equalize method is set to Manual Timer or Auto-Equalize Timer, the AT10.1 will revert to Float mode at the end of the selected equalize time.

### 2.2.4. Choosing the Equalize method

Press the **EQLZ MTHD** key to choose the desired equalize method. The indicator next to the desired equalize method will light. Three (3) equalize methods are available in the AT10.1:

- Manual Timer
- Manual Equalize
- Auto-Equalize Timer

These equalize methods are described below.

#### *Manual Timer Method*

Choose the manual timer method if you perform regularly scheduled equalize charging, or if you base your equalize charging on regular readings of the specific gravity of each cell of your battery (for lead-acid batteries). When your battery requires equalize charging, adjust the manual timer to 1-2 hours for each 100 AH of battery capacity (see Section 2.3.3 to learn how to adjust the equalize time). The battery manufacturer can help you determine the best equalizing schedule for your battery.

After you select the manual timer method, press the **CHRG MODE** key to put the AT10.1 into the equalize mode. The **EQLZ** indicator will light. When the equalize timer is finished, the AT10.1 reverts automatically to the float mode, and the **FLOAT** indicator lights.

Any time during equalize charge, you can switch the AT10.1 back to float mode by pressing the **CHRG MODE** key. The **FLOAT** indicator will light.

If there is an ac power failure during a timed equalize charge, the AT10.1 remembers the remaining equalize time. When ac power is restored, it resumes the equalize charge where it left off.

# OPERATING THE AT10.1

---

## *Manual Equalize Method*

Choose the manual equalize method when you want to equalize charge the battery, but only when you are able to monitor the battery voltage and gassing rate. After you select the manual equalize method, press the **CHRG MODE** key to put the AT10.1 into the equalize mode. The **EQLZ** indicator will light.

Press the **CHRG MODE** key again to return the AT10.1 to float mode. The **FLOAT** indicator will light.

### NOTICE

*Never leave the AT10.1 unattended in the equalize mode with the manual equalize method selected. A sustained overcharge may cause permanent damage to the battery.*

## *Auto-Equalize Timer Method*

Select the auto-equalize timer method if you have a **flooded** (non-sealed) battery that is subject to infrequent discharges, or when the battery will be discharged to at least half of its rated capacity during an ac power failure. When ac power is restored to the AT10.1, it will turn on in the equalize mode automatically, and the **EQLZ** indicator will light. At the end of the equalize charging-time that you select, the AT10.1 reverts automatically back to float mode, and the **FLOAT** indicator lights. At any time during the equalize charge, you can switch the AT10.1 back to float mode by pressing the **CHRG MODE** key. The **FLOAT** indicator will light.

*Consult your battery manufacturer's instructions before using the auto-equalize timer method with sealed (valve-regulated) lead-acid batteries.*

Whenever the ac supply fails for 12 seconds or longer, the auto-equalize timer is enabled. For shorter periods, the timer behaves as listed below:

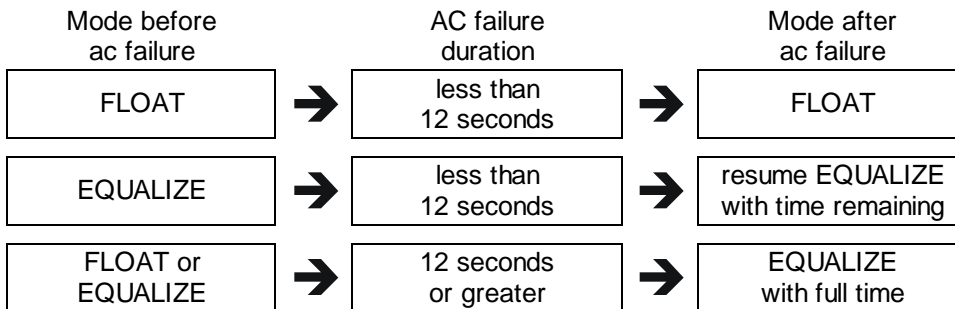

## *Switching to Equalize Mode with Auto-Equalize Timer Method Selected*

You can start an equalize charge at any time.

- Press the **CHRG MODE** key. The **EQLZ** indicator lights.

When the equalize timer is finished, the AT10.1 reverts automatically to float mode, and the **FLOAT** indicator lights.

## 2.2.5. Testing the front panel indicators

- Press the **DOWN** key. This is also the **LAMP TEST** key.

The meter will display **8888**, and all status & alarm indicators will light.

The **LAMP TEST** key does not test the **AC ON** indicator. The **AC ON** indicator lights whenever ac power is present and the ac circuit breaker is turned on. The **LAMP TEST** key does not operate when ac power is off.

To test the action of the AT10.1 summary alarm relay, press and hold the **LAMP TEST** key for 4 seconds to transfer the relay. If you are monitoring the relay with a remote annunciator, it will detect the alarm condition.

## 2.2.6. Testing the Auxiliary Alarm Relay PC Board (optional)

If you have the optional Auxiliary Alarm Relay PC Board (A5) installed, you can similarly test the six (6) individual alarm relays. Press and hold the **LAMP TEST** key for 4 seconds to transfer the relays. If you are monitoring the relays with a remote annunciator, it will detect the alarm conditions.

## 2.2.7. Interpreting the alarm indicators

There are six (6) red LED alarm indicators at the right side of the front panel. An indicator lights for each of the following alarm conditions:

- **HIGH DC VOLTAGE:** DS13 lights whenever the dc output voltage exceeds the specified alarm voltage setting. See Section 2.3.4 to learn how to adjust the HVDC alarm setting.
- **LOW DC VOLTAGE:** DS14 lights whenever the dc output voltage is below the specified alarm voltage setting. See Section 2.3.4 to learn how to adjust the LVDC alarm setting.
- **DC OUTPUT FAILURE:** DS15 lights whenever the AT10.1 cannot provide its full rated output voltage *or* its full rated output current. This alarm setting cannot be adjusted.
- **AC INPUT FAILURE:** DS16 lights whenever the ac power supply to the AT10.1 is interrupted.
- **POS GND:** DS17 lights whenever leakage current from the battery positive (+) terminal to ground exceeds a specified threshold. \*
- **NEG GND:** DS18 lights whenever leakage current from the battery negative (-) terminal to ground exceeds a specified threshold. \*

*\* The ground fault detection sensitivity can be adjusted from 5 to 30 k $\Omega$ , see Section 2.3.4 on page 34.*

When an alarm occurs, the indicators will light immediately. The AT10.1 also features a summary alarm relay with one (1) form-C contacts (TB3) rated 0.5A / 125 Vac/Vdc. If an alarm condition lasts for 30 seconds or longer, the summary alarm relay transfers. Under standard settings, when the alarm condition is corrected, the corresponding relay and indicator resets automatically. Latching alarm capability for the AT10.1 is available, featured in supplemental *Operating Instructions* ([JA5098-00](#)).

# OPERATING THE AT10.1

---

## 2.3. SETTING PARAMETERS IN THE AT10.1

### 2.3.1. Understanding Parameter Settings

You can change the settings of the AT10.1 while it is operating, using the front panel controls. The changes you make take effect immediately, and are saved internally. If the AT10.1 is taken out of service, and then later returned to service, it restarts using the last values you set. You can adjust the following parameters:

- Float voltage
- Equalize voltage
- Equalize timer (in hours)
- High dc voltage alarm setting
- Low dc voltage alarm setting
- Current Limit value (in Amperes)
- High dc voltage shutdown feature (on or off)

Your choice of equalize method is also saved internally.

When you want to change any parameter, press the **EDIT/ENTER** key to put the AT10.1 into **Edit Mode**. The meter display flashes about once per second, and the status indicators prompt you to adjust the respective parameter. Adjust each parameter by pressing the **UP** or **DOWN** key until the meter displays the desired reading. You can make the display scroll up or down continuously by pressing and holding the **UP** or **DOWN** key.

You cannot exceed certain upper and lower limits for the operating parameters. To see what the limits are for your AT10.1, refer to the Specifications in Appendix A on page 70.

When you first press the **EDIT/ENTER** key, the AT10.1 prompts you to adjust the first parameter in the list above (float voltage). When you obtain the value you want on the display, press the **EDIT/ENTER** key again. The AT10.1 saves the new setting internally, and then prompts you to adjust the second parameter. You continue this way to adjust the first six (6) parameters in the list above. If you want to skip adjusting any parameter, just press the **EDIT/ENTER** key again. The AT10.1 moves to the next parameter.

When you are finished adjusting the sixth parameter (Current Limit), press the **EDIT/ENTER** key again. The AT10.1 saves all adjustments you made internally, and reverts to normal operation. The new settings take effect immediately.

If you do not press any front panel key for 25 seconds, **Edit Mode** ends automatically, and any change you made to the last setting is not saved.

## 2.3.2. Setting the Float and Equalize voltages

- Press the **EDIT/ENTER** key.

The **FLOAT** and **DC VOLTS** indicators light, and the display flashes the present value of the float voltage. Press and release the **UP** or **DOWN** key to increase or decrease the value in the display by one count, or press and hold the **UP** or **DOWN** key to scroll the value in the display upward or downward. When the meter displays the desired float voltage, release the **UP** or **DOWN** key. If you go past the voltage you want, press the **UP** or **DOWN** key again to reach the voltage you want to set.

- Press the **EDIT/ENTER** key. The new float voltage setting is saved internally.

The **EQLZ** and **DC VOLTS** indicators light, and the display flashes the present value of the equalize voltage. Press and release the **UP** or **DOWN** key to increase or decrease the value in the display by one count, or press and hold the **UP** or **DOWN** key to scroll the value in the display upward or downward. When the meter displays the desired equalize voltage, release the **UP** or **DOWN** key. If you go past the voltage you want, press the **UP** or **DOWN** key again to reach the voltage you want to set.

- Press the **EDIT/ENTER** key. The new equalize voltage setting is saved internally.

If you want to adjust the equalize timer duration, skip to Section 2.3.3.

**OR**

If you want to exit the **Edit Mode** now, press the **EDIT/ENTER** key four (4) more times until the AT10.1 returns to normal operation.

If you do not press any front panel key for 25 seconds, **Edit Mode** ends automatically, and any change you made to the last setting is not saved.

# OPERATING THE AT10.1

---

## 2.3.3. Setting the Equalize Timer

- Press the **EDIT/ENTER** key until the **EQLZ HRS REMAINING**, **MANUAL TIMER** and **AUTO EQLZ TIMER** indicators all light. The display will flash the present value (hours) of the equalize timer duration.

Press and release the **UP** or **DOWN** key to increase or decrease the value on the display by one count. Press and hold the keys to scroll the values upward or downward. If a desired value is passed, press the opposite key to fine tune. When the meter displays the desired equalize time (in hours), release the **UP** or **DOWN** key. The maximum value is 255 hours.

*If you set the equalize time to zero hours, the equalize mode is **disabled**.*

- Press the **EDIT/ENTER** key. The new equalize timer duration is saved internally. The timer setting works for both the manual timer and the auto-equalize timer.

If you want to adjust the alarm settings, skip to Section 2.3.4.

**OR**

If you want to exit the **Edit Mode** now, press the **EDIT/ENTER** key three (3) more times until the AT10.1 returns to normal operation.

## 2.3.4. Setting the Alarms

After you save the equalize timer setting, the **Edit Mode** automatically prompts you to adjust the settings of the high dc voltage and low dc voltage alarms. There is a red indicator light on the front instrument panel of the AT10.1 for each of the following alarm conditions:

- High DC Voltage
- Low DC Voltage
- DC Output Failure
- AC Input Failure
- Positive (+) Ground Fault Detection
- Negative (-) Ground Fault Detection

When an alarm occurs, the indicator LEDs will light immediately. The AT10.1 also features a summary alarm relay with one (1) form-C remote contacts (TB3), rated 0.5A / 125 Vac/Vdc. If an alarm condition lasts for 30 seconds or longer, the summary alarm relay contacts transfer. When the alarm condition is corrected, the relay and all indicators reset automatically. If latching alarms/relays are enabled the relay will need to be reset manually, see Section 2.2.7 on page 29.

The summary alarm relay also transfers when the AT10.1 detects certain secondary errors, indicated by meter display codes rather than a discrete front panel red LED. Codes **E 01** through **E 13**, and **A 01** will trigger the summary alarm. See Section 3.2 on page 45 for all error and status codes.

### *Setting the High DC Voltage Alarm*

- Press the **EDIT/ENTER** key until the **HIGH DC VOLTAGE** indicator flashes, and the display flashes the present value of the high dc voltage alarm.

Press and release the **UP** or **DOWN** key to increase or decrease the value in the display by one count, or press and hold the **UP** or **DOWN** key to scroll the value in the display upward or downward. When the meter displays the desired high dc voltage alarm point, release the **UP** or **DOWN** key. If you go past the voltage you want, press the **UP** or **DOWN** key again to reach the voltage you want to set.

- Press the **EDIT/ENTER** key. The new high dc voltage alarm setting is entered into permanent memory.

### *Setting the Low DC Voltage Alarm*

- Press the **EDIT/ENTER** key until the **LOW DC VOLTAGE** indicator flashes, and the display flashes the present value of the low dc voltage alarm.

Press and release the **UP** or **DOWN** key to increase or decrease the value in the display by one count, or press and hold the **UP** or **DOWN** key to scroll the value in the display upward or downward. When the meter displays the desired low dc voltage alarm point, release the **UP** or **DOWN** key. If you go past the voltage you want, press the **UP** or **DOWN** key again to reach the voltage you want to set.

- Press the **EDIT/ENTER** key. The new low dc voltage alarm setting is entered into permanent memory.

If you want to adjust the Current Limit setting, skip to Section 2.3.5.

**OR**

If you want to exit the **Edit Mode** now, press the **EDIT/ENTER** key again to return the AT10.1 to normal operation.

# OPERATING THE AT10.1

## Adjusting Ground Detection Sensitivity

The AT10.1 ground detection alarm sensitivity is adjustable from 5 to 30 k $\Omega$ . You must have a small jeweler's screwdriver for adjustment, along with a "test resistor" whose Ohmic value is sized for the required ground sensitivity.

The ground detection sensitivity is adjusted equally (+/-) from 5 to 10 k $\Omega$ , but slightly less equally from 10 to 30 k $\Omega$ . Adjustments are made via potentiometer labeled **RA3 SENS**, located on the Main Control PC Board (A1), as shown in the figure at the right.

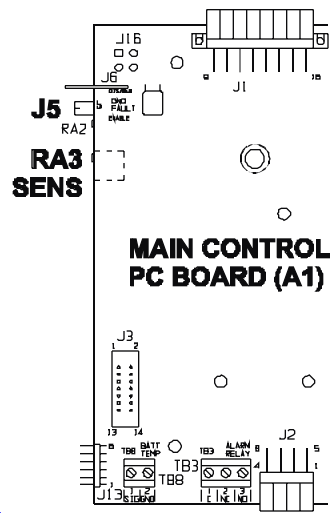

### NOTICE

*Do not try to adjust the upper potentiometer labeled **RA2 BALANCE**. This adjustment is made at the factory for proper circuit operation.*

### ⚠ CAUTION

*Before connecting or disconnecting a test resistor to the AT10.1, de-energize and lock out all ac and dc voltage sources.*

*Check with a voltmeter before proceeding. Restart the AT10.1 only when necessary to make the sensitivity adjustment. If your battery is grounded, do not attempt this procedure.*

Remove the Plexiglas safety shield at the I/O panel board. Connect the test resistor between **TB1(+)** and ground. Adjust **RA3** counter-clockwise until the front panel indicator goes out, then adjust clockwise until the **POS GND** indicator *just* lights. Make this adjustment slowly, since the indicator is only updated once every 4 seconds.

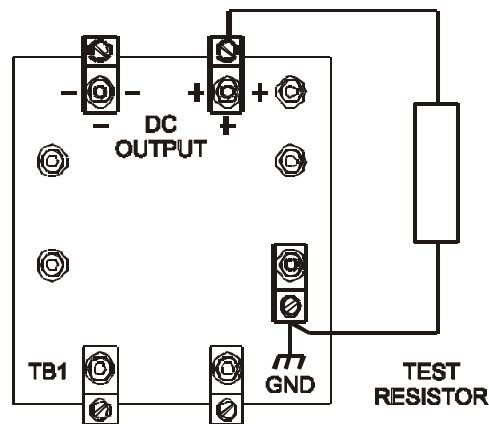

De-energize and lock out power to the AT10.1. Remove the test resistor at **TB1(+)** and verify the **POS GND** indicator goes out. Connect the test resistor between **TB1(-)** and ground. Verify that the **NEG GND** indicator lights. If not, adjust **RA3** clockwise until it *just* does.

Remove the test resistor and return the AT10.1 to normal operation.



## *Using Ground Detection in Charger Standby Mode*

If you put the AT10.1 into standby mode by opening the dc circuit breaker (CB2), the ground detection circuit will send an erroneous *positive* (+) ground fault alarm. There are two (2) ways to work around this:

- Disable the ground detection circuit while the AT10.1 is in standby, as described below.
- Put the AT10.1 into standby by opening the ac input circuit breaker (CB1), and leaving the dc output circuit breaker (CB2) closed.

Operating the AT10.1 with the ac breaker (CB1) closed, but the dc breaker (CB2) open, is an *abnormal* condition. It is not recommended.

## *Disabling the Ground Detection Alarm*

You can disable the ground detection alarm circuit, and isolate the circuit from chassis ground. If your battery is normally grounded, or you want to defeat the alarm for any other reason, follow these steps:

- Shut down the AT10.1 and lock out all ac and dc voltage sources. This includes alarm and remote sense wires if they were installed. Open the front panel door and check with a voltmeter before proceeding.
- Locate jumper **J5** at the top left of the Main Control PC Board (A1) as shown on the previous page. Move the jumper to the **DISABLE** position. The **POS GND** and **NEG GND** indicators and the summary alarm relay (TB3) will not respond to a ground fault.

Restart the AT10.1, following the instructions in Section 2.1.

### **2.3.5. Setting the Current Limit value**

The AT10.1 automatically limits its dc output current in case of overload or battery discharge. You can adjust the value of the Current Limit from 50% to 110% of rated current. The factory setting is 110%.

The Current Limit adjustment is the last step in the normal **Edit Mode** sequence. If the AT10.1 is not in the **Edit Mode**, press the **EDIT/ENTER** key six (6) times, until the meter display flashes the value of the Current Limit setting (in Amperes). Press and release the **UP** or **DOWN** key to increase or decrease the value in the display by one count, or press and hold the **UP** or **DOWN** key to scroll the value in the display upward or downward. When the meters display the desired Current Limit value, release the **UP** or **DOWN** key. If you go past the number you want, press the **UP** or **DOWN** key again to reach the number you want to set.

- Press the **EDIT/ENTER** key.
- The new Current Limit setting is saved internally.
- The front panel display will flash **End** to confirm.

If you do not press any front panel key for 25 seconds, **Edit Mode** ends automatically, and any change you made to the last setting is not saved.

# OPERATING THE AT10.1

---

## 2.3.6. Enabling the High DC Voltage shutdown feature

The AT10.1 has a built-in high dc voltage shutdown feature. In case of any maladjustment or internal failure that results in a continuous output voltage that is too high, the AT10.1 shuts down after 30 seconds to protect the battery. The front panel meter displays code **E 03**, and the summary alarm relay contact (TB3) transfers.

### NOTICE

*The AT10.1 is normally shipped from the factory with the High DC Voltage Shutdown feature **disabled**.*

You can adjust the high dc voltage shutdown (the setting is the same as the high dc voltage alarm setting). Refer to Section 2.3.4.

To enable the shutdown feature:

- The AT10.1 must be in normal operation (not the **Edit Mode**) to enable HVDC Shutdown.
- Press and hold the **UP** key, then...
- Press the **CHRG MODE** key.

The **HIGH DC VOLTAGE** indicator lights, and the display flashes **ON**. You can toggle the shutdown feature **OFF** and **ON** by pressing the **CHRG MODE** key repeatedly.

**Parallel Operation**  
If two (or more) AT10.1s are connected in parallel, both sense the output voltage. If one AT10.1 runs away, it will supply all the output current. The other will have zero output current. The high dc voltage shutdown does not operate in an AT10.1 with zero output current, so that only the *defective* AT10.1 (of two or more in parallel) shuts down. The other AT10.1 will continue to supply the load normally.

If you do not press any key within 4 seconds, the last state indicated (**ON** or **OFF**) is saved internally. Note that you *do not* use the **EDIT/ENTER** key for this feature.

If the AT10.1 shuts down because of a high dc voltage, the meter displays error code **E 03**. Reset the AT10.1 by turning the ac input circuit breaker (CB1) off, then on again.

## 2.3.7. Adjusting the Voltmeter Accuracy

The AT10.1 voltmeter is adjusted at the factory to display the actual output voltage within  $\pm 0.25\%$ . If you replace any component that affects meter accuracy, such as the Main Control PC Board (A1) or resistor (R4), you should readjust the meter. This adjustment procedure is different from all others, because the meter reading remains constant, while the output voltage of the AT10.1 changes. Do this adjustment with a fully charged battery and no load connected.

- Enter **Edit Mode** to adjust the AT10.1 float voltage to the desired value. See Section 2.3.2 on page 31 for instructions on setting the float voltage.
- After entering the float voltage, exit **Edit Mode** by pressing the **EDIT/ENTER** key four (4) times until the AT10.1 returns to normal operation. If you do not press any front panel key for 25 seconds, **Edit Mode** ends automatically, and any change made to the last setting is not saved.
- After successfully exiting **Edit Mode**, you may adjust the voltmeter accuracy. Press and hold the **UP** key, then press the **EQLZ MTHD** key.
- The **DC VOLTS METER MODE** indicator will light, and the front panel display flashes the dc output voltage reading.
- Measure the AT10.1 dc output voltage using a meter accurate to  $\pm 0.25\%$  or better.
- While watching the meter *connected* to the AT10.1 output (not the front instrument panel display), press the **UP** or **DOWN** key until the actual (meter) output voltage matches the float setting on the front panel display.

### NOTICE

*Allow 1-2 seconds for the output voltage to stabilize each time you press the **UP** or **DOWN** key.*

Each time you press **UP** or **DOWN**, you change the AT10.1 output voltage by a small amount. Continue to press **UP** or **DOWN** until the actual (measured) output voltage agrees with the front panel display reading within  $\pm 0.25\%$ .

- When you are finished adjusting the output voltage, the AT10.1 waits 5 seconds before the front panel display automatically returns to normal operation.

# OPERATING THE AT10.1

## 2.3.8. Using the Low Level Detector (LLD)

The AT10.1 is equipped with a summary (common) alarm relay safety override circuit. This feature forces the alarm relay contact to transfer, sending an alarm, even if there is a catastrophic failure of the AT10.1 control circuitry. A low battery voltage triggers the safety circuit.

Main Control PC Board (A1) hardware, not software, maintains the low level detect circuit. Therefore, to remotely monitor this alarm, user connections must be made at terminal block (TB3). The summary alarm contacts (TB4) on the Auxiliary Alarm Relay PC Board will not signal a low level detect alarm.

If you have a dc power supply, you can adjust the battery voltage that triggers the alarm. On the back of the Main Control PC Board (A1), find the potentiometer **RA1**, as shown in the figure below.

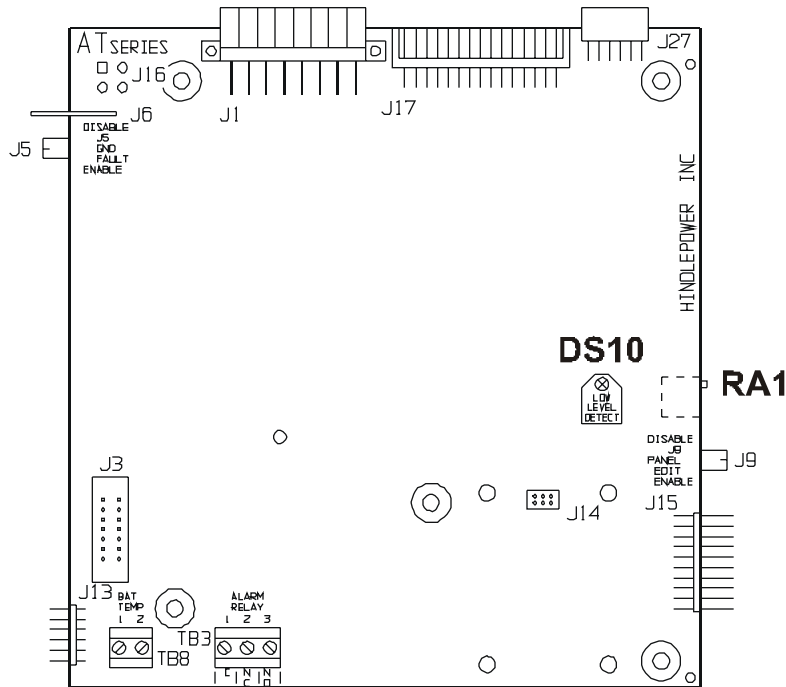

Disconnect all ac and dc power sources from the AT10.1, and connect your dc power supply to the charger dc output terminals (TB1+/-), positive to positive and negative to negative. Adjust the power supply to the voltage at which you want to activate the alarm.

### NOTICE

*You need at least 50% of the nominal output voltage to power the AT10.1 Main Control PC Board (A1).*

Adjust **RA1** with a small jeweler's screwdriver clockwise until the alarm just activates. A red LED indicator (**DS10**) next to **RA1** indicates when the alarm is active.

## 2.3.9. Using the front panel security feature

The AT10.1 is shipped from the factory with all front instrument panel keys enabled. You can disable the following front panel functions:

- Selecting Equalize method
- Changing settings using the **EDIT/ENTER** key
- Toggling the high dc voltage shutdown feature

To disable the front instrument panel keys, open the AT10.1 door and locate the small plastic jumper **J9** on the right side of the Main Control PC Board (A1). See the figure below.

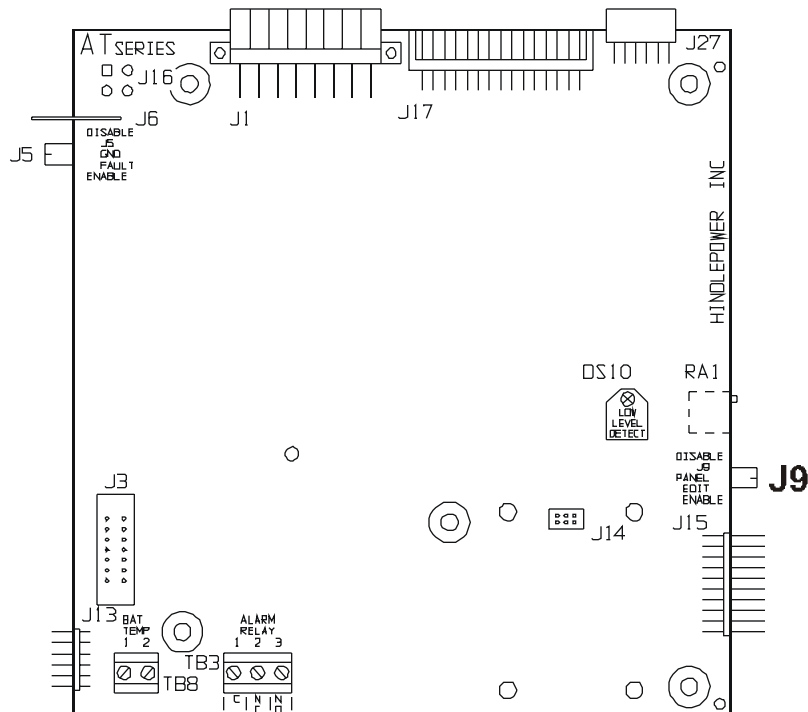

Move the jumper up to the **DISABLE** position (pins 2 and 3). With this setting, only the front panel **METER MODE** and **CHRG MODE** keys will function. All indicators will still work normally. Return the jumper down to the **ENABLE** position (pins 1 and 2) to return all front panel key functionality.

# OPERATING THE AT10.1

---

## 2.4. PERFORMING ROUTINE MAINTENANCE

**⚠ WARNING**

*High voltages appear at several points inside the AT10.1. Use extreme caution when working inside the enclosure. Do not attempt to work inside the AT10.1 unless you are a qualified technician or electrician.*

*Disconnect and lock out all power from the AT10.1 before starting to remove or replace any components. Turn the ac power off at the distribution panel upstream from the charger. Disconnect the battery from the AT10.1 output terminals TB1(+/-).*

### 2.4.1. Keep it clean

The AT10.1 is cooled by natural convection. At least once a year, vacuum the vents at the top and bottom of the enclosure to ensure that there is an adequate supply of cooling air. If you have an extremely dusty environment (especially if airborne dust is conductive), *carefully* vacuum out the interior. Clean the surfaces of circuit boards, and clean around electrical terminals.

The AT10.1 is rated for operation up to 122 °F / 50 °C. If your installation is in a warmer environment, or at an elevation over 3000ft / 914m, contact your sales representative for operating information.

### 2.4.2. Check power and signal connections

Check the tightness of all field connections inside the AT10.1, and connections to the battery. A loose or corroded connection at the battery terminals can be a fire or explosion hazard, and may cause erroneous operation of the AT10.1.

### 2.4.3. Check remote sense wiring (optional)

If you wired the AT10.1 for remote sense, check the signal connections to the battery or load, making sure insulation is in satisfactory condition. If there is a failure of the remote sense signal wiring, the AT10.1 displays the error code **E 06**. The AT10.1 returns to local control, sensing the output voltage at the charger output terminals (TB1+/-).

### 2.4.4. Check temperature compensation probe (optional)

If you are using the optional temperature compensation probe, confirm the probe (A10) is securely installed. Make sure the connectors and the wiring from the probe to the AT10.1 are in satisfactory condition.

If there is a failure of the temperature compensation probe, or the wiring, the AT10.1 displays the error code **E 08**.

### 2.4.5. Measuring the output ripple voltage (filtered models only)

If your AT10.1 is a filtered model, measure the ac ripple at the battery terminals at least once a year. Use an rms responding ac voltmeter.<sup>1</sup> If the battery Ampere-hour capacity is at least four (4) times the output current rating of the AT10.1, the ripple voltage should be no higher than the value featured in the specifications in Appendix A on page 70.

If you suspect that the output ripple voltage is too high, see "Output ripple voltage too high" of the *Troubleshooting Chart* in Section 3.4, page 53.

### 2.4.6. Viewing the voltage and alarm settings

You can review the parameter settings in the AT10.1 by pressing the **EDIT/ENTER** key on the front instrument panel. Each time you press the key, a different parameter displays, in the following order:

- Float voltage
- Equalize voltage
- Equalize time (in hours)
- High dc voltage alarm setting
- Low dc voltage alarm setting
- Current Limit (in Amperes)

---

<sup>1</sup> Do not use a dc voltmeter. The ripple voltage on a battery is a very small ac voltage.

# OPERATING THE AT10.1

## SAMPLE PREVENTIVE MAINTENANCE PROCEDURE

### AT10.1 BATTERY CHARGER ([JD0064-00](#))

Suggested Frequency: every six (6) months

Maintenance date \_\_\_\_\_ Performed by \_\_\_\_\_



*High voltages appear at several points inside the AT10.1. Use extreme caution when working inside the enclosure. Do not attempt to work inside the AT10.1 unless you are a qualified technician or electrician.*

Step (standard features)	Instructions	Results
<b>Clean AT10.1</b>	<ul style="list-style-type: none"> <li>All vents clean and open.</li> <li>Remove dust and debris from inside unit.</li> </ul>	<input type="checkbox"/> OK <input type="checkbox"/> OK
<b>Check all electrical connections and wiring</b>	<ul style="list-style-type: none"> <li>TB1 connections all tight.</li> <li>Internal wiring connections tight, slip-on connectors fully seated. Wire and lug insulation in satisfactory condition.</li> <li>Terminations at battery or dc bus are tight and corrosion free.</li> </ul>	<input type="checkbox"/> OK <input type="checkbox"/> OK  <input type="checkbox"/> OK
<b>Check ac input voltage</b>	<ul style="list-style-type: none"> <li>Measure between TB1-L1 and TB1-L2 using an ac voltmeter. Value must be within +10% &amp; -12% of nominal voltage.</li> </ul>	Input _____ Vac
<b>Check dc output voltage</b>	<ul style="list-style-type: none"> <li>Measure at TB1(+) and TB1(-) using a dc voltmeter. Value should agree with front panel voltmeter within +/-0.25%, and must be correct values for your battery. If the AT10.1 is using a temperature compensation probe, see the graph on page 23 to determine correct battery voltage. You need to know the battery temperature for this step.</li> </ul>	Float _____ Vdc  Equalize _____ Vdc
<b>Check ripple voltage</b>	<ul style="list-style-type: none"> <li>Measure at battery terminals using an ac voltmeter set to the milliVolts scale. Check against specification in Appendix A on page 70.</li> </ul>	Ripple _____ mVac
<b>Test font panel indicators</b>	<ul style="list-style-type: none"> <li>Press the <b>LAMP TEST</b> key on the front panel.</li> </ul>	<input type="checkbox"/> OK
<b>Test summary alarm relay</b>	<ul style="list-style-type: none"> <li>Press the <b>LAMP TEST</b> key and <i>hold</i> for 4 seconds. The summary alarm relay at TB3 will transfer.</li> </ul>	<input type="checkbox"/> OK



# OPERATING THE AT10.1

<b>Exercise front panel controls</b>	<ul style="list-style-type: none"> <li>Switch from float to equalize, then back to float.</li> <li>Turn off the dc circuit breaker. <b>E 07</b> may appear on display (requires at least 5% of rated output current). Reset breaker.</li> </ul>	<input type="checkbox"/> OK  <input type="checkbox"/> OK
	<ul style="list-style-type: none"> <li>Cycle through meter modes.</li> </ul>	<input type="checkbox"/> VOLTS OK <input type="checkbox"/> AMPERES OK <input type="checkbox"/> HOURS OK
	<ul style="list-style-type: none"> <li>Cycle through equalize methods.</li> </ul>	<input type="checkbox"/> MANUAL TIMER OK <input type="checkbox"/> MANUAL EQLZ OK <input type="checkbox"/> AUTO EQLZ TIMER OK
	<ul style="list-style-type: none"> <li>Turn off ac circuit breaker. The <b>AC INPUT FAILURE</b> indicator should light. Reset breaker.</li> </ul>	<input type="checkbox"/> Alarm OK
<b>Check voltage and alarm settings</b>	<ul style="list-style-type: none"> <li>Use <b>EDIT/ENTER</b> key to scroll through settings. See page 30.</li> </ul>	<input type="checkbox"/> FLOAT OK <input type="checkbox"/> EQUALIZE OK <input type="checkbox"/> HVDC alarm OK <input type="checkbox"/> LVDC alarm OK Current Limit _____ Adc
<b>Final checks</b>	<ul style="list-style-type: none"> <li>Make sure Plexiglas safety shield is in place.</li> <li>Restore AT10.1 to normal operation.</li> <li>Close latch on front panel.</li> </ul>	<input type="checkbox"/> OK  <input type="checkbox"/> OK <input type="checkbox"/> OK

Step (optional features)	Instructions	Results
<b>Test auxiliary alarm relays</b>	<ul style="list-style-type: none"> <li>Press the <b>LAMP TEST</b> key and <b>hold</b> for 4 seconds. The discrete alarm relays at TB4 will transfer.</li> </ul>	<input type="checkbox"/> OK
<b>Check integrity of remote wiring</b>	<ul style="list-style-type: none"> <li>Remote sense wiring. See page 16.</li> <li>Temperature compensation wiring. See page 20.</li> <li>Temperature compensation probe. See page 20.</li> </ul>	<input type="checkbox"/> OK <input type="checkbox"/> OK <input type="checkbox"/> OK
<b>Final checks</b>	<ul style="list-style-type: none"> <li>Close padlock or key lock.</li> </ul>	<input type="checkbox"/> OK

Step (10-year repair)	Instructions	Results
<b>Replace Capacitors</b>	<ul style="list-style-type: none"> <li>Order and replace optional electrolytic filter capacitors (C1/C2).</li> </ul>	<input type="checkbox"/> OK

## ONLINE SUPPLEMENTS

Preventive Maintenance Procedure  
(downloadable worksheet)

<http://www.ATSeries.net/PDFs/JD0064-00.pdf>

# SERVICING THE AT10.1

---

## 3. SERVICING THE AT10.1

### 3.1. A STEP-BY-STEP TROUBLESHOOTING PROCEDURE

The AT10.1 is fully tested and calibrated from the factory, and should work for years with a minimum of attention. If you do encounter trouble, there are three (3) steps you should take to identify the problem and return the AT10.1 to service.

1. Check the front panel meter for an error code. The microprocessor control circuitry is able to diagnose common problems with the AT10.1, or with the installation or application. If the front panel displays an error code, see Section 3.2, *Interpreting Front Panel Error Messages*, for help in interpreting the code and solving the problem.
2. If the AT10.1 does not work properly, but there is no front panel error code, shut the unit down. Turn off (open) both front panel circuit breakers, and/or lock out ac and dc power externally. Restart the AT10.1 by restoring dc power *first*, followed by ac power second. This will return the AT10.1 to normal operation as long as there is no internal component failure.

#### NOTICE

*Perform Step 2 only once. If the AT10.1 does not resume normal operation, go on to Step 3.*

3. If the AT10.1 still does not work properly, make a list of the symptoms that you observe. Turn to *Using the troubleshooting chart* in Section 3.3. The troubleshooting chart relates common trouble symptoms to their causes, and gives the proper procedures for correcting the problem.
4. If the symptom does not appear on the troubleshooting chart, or if the recommended repair does not work, consult your sales or service representative to arrange for on-site or factory service.

## 3.2. INTERPRETING FRONT PANEL ERROR MESSAGES

If the AT10.1 control circuitry detects hardware or wiring problems, it may display an error code on the front panel meter. Certain non-error status codes are also displayed. To solve an error code problem, refer to the table below, which lists the codes and procedures to use.

**⚠ WARNING**

*High voltages appear at several points inside the AT10.1. Use extreme caution when working inside the enclosure. Do not attempt to work inside the AT10.1 unless you are a qualified technician or electrician.*

*Disconnect and lock out all power from the AT10.1 before starting to remove or replace any components. Turn the ac power off at the distribution panel upstream from the charger. Disconnect the battery from the AT10.1 output terminals TB1(+/-).*

Error Code	Meaning	Repair Procedure
<b>E 01</b>	resistor R2 open or defective	<p>The Rating Resistor (R2) is installed at the back of the front panel, in the Main Control PC Board (A1) input connector (J1). R2 is measured by the control circuitry on startup, and is used to determine some of the AT10.1 model-specific parameters, such as the float voltage.</p> <p>If the AT10.1 detects that R2 is defective (or improper), it must be replaced. See Section 3.6 for parts ordering information. When you have completed the repair, restart the AT10.1 according to Section 2.1.</p>
<b>E 02</b>	short circuit on dc output	<p>The AT10.1 may display this error code if the battery is discharged to less than 6 Volts. When the battery re-charges to greater than 6 Volts, the error code will disappear. If you have a seriously discharged battery, allow the AT10.1 to run for 24 hours and check the battery voltage again. If it has not increased to the normal voltage rating, consult the battery manufacturer for help.</p> <p>If the battery voltage is normal, check the wiring at the AT10.1 dc output terminals (TB1+/-) for a short circuit.</p> <p>If the battery voltage is normal, and all external wiring is satisfactory, check the AT10.1 dc breaker (CB2). If it is tripped, try <b>once</b> to reset it. If it trips again immediately, there may be an internal short circuit in the AT10.1. Check the internal wiring. If the AT10.1 is filtered, check the dc filter capacitors (C1/C2) and the polarity diode (CR1).</p> <p>The AT10.1 normally recovers automatically from an <b>E 02</b> condition. If you have shut down the AT10.1 for service, restart per Section 2.1.</p>
<b>E 03</b>	High DC Voltage Shutdown activated	<p>To restart the AT10.1, turn the ac breaker (CB1) off, then on. Check the Equalize voltage and High DC Voltage alarm settings. The HVDC alarm setting must be higher than the Equalize voltage setting.</p> <p>If you get another High DC Voltage shutdown after a few minutes of operation, there may be an internal component failure. See <b>AT10.1 output voltage too high, or not controllable</b> of the troubleshooting chart on page 52 in Section 3.4.</p>

## SERVICING THE AT10.1

Error Code	Meaning	Repair Procedure
<b>E 04</b>	internal memory failure	<p>Any parameters that you set, such as Float or Equalize voltage, are saved internally. The internal memory is tested on startup. If the memory test fails, <b>E 04</b> appears on the front display. The error may also appear if the controller was trying to write to the memory while a power failure occurred.</p> <p>If an <b>E 04</b> code appears, try shutting down the AT10.1. Restart by turning on the dc breaker (CB2) <b>first</b>, followed by the ac breaker (CB1). If the AT10.1 restarts normally, you must reenter any changes you made to the factory settings (float voltage, etc.).</p> <p>If <b>E 04</b> appears repeatedly, the internal memory has been damaged. You must replace the Main Control PC Board (A1). See Section 3.6 for parts ordering information.</p>
<b>E 05</b>	<i>not used</i>	This error code was formerly used to indicate a reverse battery connection. It is not available in the AT10.1.
<b>E 06</b>	defective R4 or R14 resistor, or remote sense wiring failure	<p>Identify the Positive (+) Scaling Resistor (R4) mounted to TB5, on the back side of the front instrument panel. Remove the resistor and measure its value with an Ohmmeter (see table 3-1 for the correct value). If the resistor is not within 1% of the specified value, it must be replaced.</p> <p>Identify the Negative (-) Scaling Resistor (R14) inside the enclosure, connected to TB1(-). Remove the lugged end and measure the resistor's value with an Ohmmeter (see table 3-1 for the correct value). If the resistor is not within 1% of the specified value, it must be replaced.</p> <p>If you are using remote sense wiring from the battery to the AT10.1, the wiring may have failed. The usual failure is an open circuit. A short circuit will usually be indicated by smoke or fire in the wiring.</p> <p>The AT10.1 displays error code <b>E 06</b> if it detects this wiring failure. You should respond to this problem <b>quickly</b>, to make sure the AT10.1 regulates the output voltage properly. Wire an annunciator (e.g. buzzer) to the summary alarm relay contact (TB3) for remote indication of any charger problem. Otherwise monitor the AT10.1 operation using the optional DNP3 Level 2 / Modbus Communications Module (<a href="#">JA0102-04</a>).</p> <p>If a failure exists in remote sense wiring, the AT10.1 regulates its output voltage locally until you correct the problem, see Section 1.9. The locally controlled voltage may not reflect the true requirements of the battery.</p> <p>When you complete the repair, restart the AT10.1 per Section 2.1.</p>
<b>E 07</b>	open dc breaker (CB2) or internal dc wiring failure	<p>If the dc breaker (CB2) is open, open the ac breaker (CB1). Restart by closing the dc breaker (CB2) <b>first</b>, followed by the ac breaker (CB1). If the dc breaker trips again, see the troubleshooting chart in Section 3.4.</p> <p>If the dc breaker (CB2) is closed, but the front panel meter displays <b>E 07</b>, check your battery. If the battery is disconnected, and you <b>then</b> disconnect the dc load, the AT01.1 may display an <b>E 07</b> code. Restart the AT10.1 according to Section 2.1.</p> <p>If the battery and dc load are satisfactory, see the troubleshooting chart in Section 3.4 for help in locating the problem.</p>
<b>E 08</b>	defective temperature compensation probe	<p>See <b>Application Note</b> (<a href="#">JD5003-00</a>) for more detailed user instructions.</p> <p>If a remote temperature compensation probe (A10) is connected to the AT10.1, the control circuitry detects the probe on startup and uses the temperature measured by the probe to control the output voltage of the charger. To understand temperature compensation, see Section 1.11.</p> <p>If the probe (A10) or the wiring that connects it to the Main Control PC Board (A1) fails during normal operation, the AT10.1 detects the failure and displays <b>E 08</b> on the front panel meter.</p>

## SERVICING THE AT10.1

Error Code	Meaning	Repair Procedure
<b>E 08</b>	defective temperature compensation probe <i>(continued)</i>	Disconnect the wiring at the probe and measure the resistance across the quick-connect leads with an Ohmmeter. The resistance should measure approximately 10,000 $\Omega$ at normal room temperature (77 °F / 25 °C). If the probe reads open or shorted, it needs to be replaced.  If the probe is satisfactory, examine the wiring between the probe and the AT10.1. Also, check the connection of the cable to TB8 on the Main Control PC Board (A1) on the back of the front panel. If the wiring is satisfactory, the probe needs to be replaced. Once you have replaced the probe, you must restart the AT10.1 to activate temperature compensation.
<b>E 09</b>	misadjusted Current Limit	This code has been discontinued with Main Ctrl PCB firmware version 6.52. See <b>Application Note</b> ( <a href="#">JD5035-00</a> ) for a description of this code.
<b>E 10</b>	open internal feedback loop	A redundant internal feedback loop (control loop) is provided to increase reliability when remote sensing is used. If there is a problem with the internal loop wiring, the front panel meter will display <b>E 10</b> .  Check the internal wiring in the signal harness, especially wire # <b>33</b> . Also check the harness connector (J1) on the Main Control PC Board (A1).
<b>E 12</b>	defective internal thermostat	The AT10.1 rectifier heat sink assembly has been equipped with a <b>non-standard</b> over-temperature thermostat (S2). On startup, the AT10.1 tests the thermostat, and displays <b>E 12</b> if it is defective.  Check the thermostat (S2) for continuity. Disconnect the wiring and resistor (R28) from the quick-connect terminals. The thermostat switch should be closed (NC) at normal room temperature.
<b>E 13</b>	internal over-temperature	The non-standard rectifier thermostat (S2) has detected an over-temperature condition. If the rectifier is equipped with a fan (B2), check the fan for proper operation. Also make sure that all enclosure vents are clear of debris, and that the ambient temperature is below 122 °F / 50 °C.
<b>E 14</b>	forced load sharing not working properly	See Appendix F on page 90.  Verify both AT10.1s are functioning properly. Ensure that the forced load sharing interconnection cable assembly is not broken, is properly installed, and that the connector for the Secondary charger has the jumper as described. Ensure that both AT10.1s are connected to the same ac supply, and that source phase rotation is the same for both AT10.1s.
<b>E 15</b>	battery open	The AT10.1 has detected an open battery, see Appendix J on page 94.
<b>E 16</b>	remote shutdown	The AT10.1 has been shut down remotely, see Appendix H on page 93.
<b>A 01</b>	manual eqlz enabled for more than 24 hr	If the AT10.1 was accidentally left in manual equalize mode, switch the unit back to float, manual equalize timer, or auto-equalize timer mode, according to Section 2.2.4 on page 27.
<b>A 02</b>	equalize mode inhibited	If you set the equalize timer to zero (0) hours, the equalize mode is inhibited. When you try to put the AT10.1 into equalize mode from the front panel controls, the meter displays status code <b>A 02</b> . If you want to enable the equalize mode, set the equalize timer to one (1) or more hours.
<b>A 04</b>	voltmeter calibration inhibited w/TempCo active	While using temperature compensation, the AT10.1 internal dc voltmeter cannot be calibrated. Disconnect one wire of the TempCo cable from TB8 on A1. Restart the AT10.1 and perform the voltmeter calibration according to Section 2.3.7 on page 37. Reconnect the TempCo cable to TB8, and restart the AT10.1. See <b>Application Note</b> ( <a href="#">JD5003-00</a> ) for further details.
<b>A 05</b>	dc output at Current Limit setting	The AT10.1 is in Current Limit mode. This will occur when there is a large load on the dc bus, or the battery has discharged. Make sure that the AT10.1 is sized correctly for the application, and that the Current Limit value has been set correctly. See Section 2.3.5 on page 35.

# SERVICING THE AT10.1

---

## 3.3. USING THE TROUBLESHOOTING CHART

**⚠ WARNING**

*High voltages appear at several points inside the AT10.1. Use extreme caution when working inside the enclosure. Do not attempt to work inside the AT10.1 unless you are a qualified technician or electrician.*

*Disconnect and lock out all power from the AT10.1 before starting to remove or replace any components. Turn the ac power off at the distribution panel upstream from the charger. Disconnect the battery from the AT10.1 output terminals TBI(+/-).*

Before you try to use the troubleshooting chart, confirm you have followed the steps in Section 3.1.

The troubleshooting chart that begins on the next page is divided into three (3) columns. To use the chart:

1. Make a list of the AT10.1's condition, including the trouble symptoms.
2. Find the symptom(s) in the first column of the chart.
3. The middle column contains common causes for the problem you observe, in order of probability.
4. Follow the action described in the right-hand column to correct the problem and return the AT10.1 to normal service.

### ***Determining the condition of the AT10.1:***

- Is the front panel **AC ON** indicator lit?
- What is the ac voltage at the input terminals (measured with an ac voltmeter)?
- What is the dc voltage at the output terminals (measured with a dc voltmeter)?
- Does the front panel meter display any voltage or current?
- Are any alarm indicators lit?
- Do the front panel status indicators work (Charge Mode, for example)?
- Can you change the AT10.1 to the Equalize mode, then back to Float?
- Is the AT10.1 making any noise? Is it unusually loud?
- Is there any sign or smell of smoking or burning?

While using the Troubleshooting Chart, refer to the internal component layout drawings and connection diagrams in Appendix C. For instructions on replacing components, see Section 3.5.

## 3.4. TROUBLESHOOTING CHART

SYMPTOM	PROBABLE CAUSE	RECOMMENDED ACTION
Front panel meter displays all segments <b>on</b> or all segments <b>off</b> AT10.1 may have no output	1. An external surge has interrupted operation of the microprocessor or the display controller.	1A. Soft Reset of control board by pressing S7 reset switch. S7 is located inside the AT10.1, on the control board's right edge (as viewed from the rear of the front panel). This will restart the control board without modifying any settings. 1B. Hard Reset of control board by pressing and holding the <b>UP</b> button on the front instrument panel, and simultaneously pressing S7 reset switch. This will restart the control board and restore all settings to factory default. Reset parameters per Section 2.3 of this manual. 1C. Remove all power from the AT10.1 to allow the control board to discharge internal voltages. Open the ac input circuit breaker (CB1) and disconnect all plugs on the Main Control PC Board (A1). Keep power removed for approximately 5 minutes to allow voltages to discharge. Reconnect & restart.
AC breaker (CB1) trips immediately	1. Shorted rectifier diode or SCR in module (A6)  2. Defective wiring to transformer or rectifier  3. Defective transformer	1. Disconnect wire # <b>12</b> from the Gate Driver PCB (A3). Test the SCR module (A6) by measuring resistance between the two top terminals, labeled "AC" on the schematic. Check both polarities. It should be at least 100,000 $\Omega$ . If resistance is low in either direction, replace the entire rectifier assembly (A6). 2. Check spacing of terminals. Check wiring for signs of insulation damage, burns, etc. Repair as necessary.  3. Test by disconnecting wires from X1, X4, Y1 and Y2. If ac breaker still trips, replace the transformer (T1).
AC breaker (CB1) trips after a few minutes	1. Loose connection to ac breaker  2. Wrong ac voltage, or T1 taps mis-wired  3. Open SCR  4. SCR not controllable	1. Check and tighten connections as required.  2. Confirm the transformer primary taps (T1-H#) are wired correctly for your ac input voltage supply. See Section 1.6 for details. 3. Use a clamp-on ammeter to measure the current in wires # <b>11</b> and # <b>12</b> (between the transformer and rectifier). If it less than 70% of the dc output current, one of the SCRs or diodes is defective. Replace the entire rectifier assembly (A6). 4. Disconnect wire # <b>24</b> from terminal E3 of the Gate Driver PC Board (A3). Restart the AT10.1. If you are able to measure output current, the SCR module is defective. Test and replace the entire rectifier assembly (A6).
DC breaker (CB2) trips immediately	1. Battery connected with reverse polarity  2. Defective rectifier bridge (if AT10.1 is UN-filtered)	1. Check battery wiring. Correct if necessary.  2. Disconnect wire # <b>12</b> from the Gate Driver PCB (A3). Test the SCR module (A6) by measuring resistance between the two top terminals, labeled "AC" on the schematic. Check both polarities. It should be at least 100,000 $\Omega$ . If resistance is low in either direction, replace the entire rectifier assembly (A6).

# SERVICING THE AT10.1

SYMPTOM	PROBABLE CAUSE	RECOMMENDED ACTION
DC breaker (CB2) trips immediately <i>(continued)</i>	<p>3. Defective free-wheeling diode in SCR module</p> <p>4. Defective polarity diode, if dc filter assembly is installed</p> <p>5. Defective wiring</p>	<p>3. Remove wire # <b>13</b> from the rectifier Gate Driver PC Board (A3). Test the A16 SCR module's internal free-wheeling diode by measuring the resistance from E2 to E10 on A3 with an Ohmmeter. The reading should be at least 100,000 <math>\Omega</math> in one polarity, and less than 1,000 <math>\Omega</math> in the other polarity. If it is defective, replace the entire rectifier assembly (A6).</p> <p>4. Remove wire # <b>15</b> from terminal E14 on the diode (CR1/CR2) heat sink. Measure resistance from the heat sink to E8 on the Gate Driver PC Board (A3). Check both polarities. If the resistance is less than 1,000 <math>\Omega</math> in both directions, replace the entire filter assembly (A7).</p> <p>5. Check spacing of terminals. Check wiring for signs of insulation damage, burns, etc. Repair as necessary.</p>
DC breaker (CB2) trips after a few minutes	<p>1. Loose connection to breaker</p> <p>2. Open SCR</p> <p>3. SCR not controllable</p> <p>4. Defective Main Control PC Board (A1)</p>	<p>1. Check and tighten connections as required.</p> <p>2. Use a clamp-on ammeter to measure current in wires # <b>11</b> and # <b>12</b>, between the transformer (T1) and the Gate Driver PC Board (A3). If it less than 70% of the dc output current, the SCR module (A16) is defective. Replace the entire rectifier assembly (A6).</p> <p>3. Disconnect wire # <b>24</b> from terminal E3 of the Gate Driver PC Board (A3). Restart the AT10.1. If you are able to measure dc output current, the SCR module (A16) is defective. Replace the entire rectifier assembly (A6).</p> <p>4. If the front panel meter displays more than 110% of the AT10.1's rated dc output current, the control board may be defective. Disconnect wire # <b>24</b> as above. If the output current goes to zero, replace the Main Control PC Board (A1).</p>
No output current, but <b>AC ON</b> lamp is <i>out</i> ac & dc breakers are on	<p>1. Site ac supply failure</p> <p>2. Optional ac input fuse (F1) is blown (480 Vac M/H input only)</p> <p>3. Defective wiring</p> <p>4. Defective transformer (T1)</p>	<p>1. If <b>AC ON</b> indicator is out, check the external (site) feeder circuit breaker or input fuses.</p> <p>2. Remove the input fuse from its box holder (located on the bottom of the enclosure) and check with an Ohmmeter or fuse tester. Replace the ac input fuse (F1) if required.</p> <p><b>NOTICE</b> If the replacement fuse blows, see the sections titled "AC breaker trips immediately" and "AC breaker trips after a few minutes" for further troubleshooting hints.</p> <p>3. Check the terminals and all wiring in between the transformer secondary (T1-X#) and the dc output terminals (TB1+/-). Check wire # <b>29</b> from T1-Y1 and wire # <b>28</b> from T1-Y2 to the Main Control PC Board connector (A1-J1). Repair wiring as necessary.</p> <p>4. Use an ac voltmeter to measure the <b>secondary</b> potential from T1-X1 to X4. It is normally 50% to 80% higher than the rated dc output voltage. If it is too low, check the <b>primary</b> tap wiring. See Section 1.6 for details. If the primary (T1-H#) voltage is 0 Vac, replace the main power transformer (T1).</p>



## SERVICING THE AT10.1

SYMPTOM	PROBABLE CAUSE	RECOMMENDED ACTION
<p>No output current, but <b>AC ON</b> lamp is <i>on</i></p> <p>ac &amp; dc breakers (CB1/CB2) are on</p>	<ol style="list-style-type: none"> <li>1. Battery is fully charged</li> <li>2. Float or Equalize Vdc is set too low</li> <li>3. Wrong ac input voltage, or T1 mis-wired</li> <li>4. Defective wiring</li> <li>5. Defective SCR module</li> <li>6. Defective Main Ctrl PC Board (A1)</li> <li>7. Defective transformer</li> <li>8. Defective inductor (L1 or L2)</li> <li>9. Defective dc output circuit breaker (CB2)</li> <li>10. Defective blocking diode</li> </ol>	<ol style="list-style-type: none"> <li>1. This is normal operation in a charger/battery system with little or no dc load. As long as the AT10.1 maintains Float voltage, it is operating normally.</li> <li>2. Check the Float and Equalize voltages and adjust them if necessary. Consult your battery manufacturer for proper voltage settings.</li> <li>3. Confirm the transformer primary taps (T1-H#) are wired correctly for your ac input voltage. See Section 1.6 for details.</li> <li>4. Check the terminals and all wiring in between the transformer secondary (T1-X#) and the dc output terminals (TB1+/-). Repair as necessary.</li> <li>5. Use an ac voltmeter to measure the voltage between terminals E3 and E4 of the Gate Driver PC Board (A3). If you measure about 1.0V rms, but there is no output current, replace the entire rectifier assembly (A6).</li> <li>6. If you do not measure any ac voltage in Step 5 above, and the battery voltage is less than the Float voltage setting, replace the Main Control PC Board (A1).</li> <li>7. Use an ac voltmeter to measure the ac voltage from T1-X1 to X4. If it is too low, check the wiring of the transformer primary taps. See Section 1.6 for details. If the ac primary (T1-H#) voltage is 0 Vdc, replace the main transformer (T1).</li> <li>8. Disconnect the wiring at the main inductor and measure the resistance between the terminals (L1-1/2). If it is an open circuit, replace the inductor (L1). If the optional dc filter is installed, repeat at inductor terminals (L2-1/2).</li> <li>9. Shut down the AT10.1 and disconnect the battery. Connect a light dc load to the AT10.1 and turn on (close) the dc circuit breaker (CB2). Measure voltage between input and output terminal(s) of the breaker. It is normally no more than 50 milliVolts. If it is near the rated dc output voltage of the AT10.1, replace the dc output circuit breaker (CB2).</li> <li>10. Disconnect wire # <b>52</b> from L2-2 to CR2. Check CR2 (both polarities) with an Ohmmeter. If CR2 is open, replace the entire filter assembly (A7). This is a very rare occurrence.</li> </ol>
<p>Front panel is dead, but ac &amp; dc voltages are present at TB1(+/-)</p>	<ol style="list-style-type: none"> <li>1. Main Control PC Board (A1) not connected</li> <li>2. Defective Main Control PC Board (A1)</li> <li>3. Defective wiring</li> </ol>	<ol style="list-style-type: none"> <li>1. Confirm the connector (J1) at the top edge of the Main Control PC Board (A1) is firmly seated.</li> <li>2. If the green <b>AC ON</b> indicator is lit, but the rest of the front panel display is dead, replace the Main Control PC Board (A1).</li> <li>3. Check the signal harness wiring to the Main Control PC Board connector (A1-J1) for signs of insulation damage, burns, etc. Confirm all wires are securely crimped in the connector.</li> </ol>

## SERVICING THE AT10.1

SYMPTOM	PROBABLE CAUSE	RECOMMENDED ACTION
Front panel dies during ac power failure, but dc voltage is present at TB1(+/-)	<ol style="list-style-type: none"> <li>1. Defective Power Supply Ballast Resistor (R3)</li> <li>2. Defective wiring</li> </ol>	<ol style="list-style-type: none"> <li>1. Use a dc voltmeter to measure voltage from TB1(-) to E17 on the I/O panel. It is normally 12 Vdc when the rated dc output voltage is present at TB1(+/-). If it is <b>not</b> 12 Vdc, remove all power from the AT10.1 and measure the resistance of R3, from TB1(+) to E17. See the table in Section 3.6 for the proper resistance value. If the resistance is not within 10% of the table value, replace R3.</li> <li>2. Remove the clear safety shield. Check the wiring to and from TB1 and the Main Control PC Board (A1) for signs of insulation damage or burns. Repair any damaged wiring.</li> </ol>
AT10.1 output voltage too high, or not controllable	<ol style="list-style-type: none"> <li>1. Defective SCR module (A16)</li> <li>2. Defective or wrong value scaling resistor (R4 or R14)</li> <li>3. Defective temperature compensation probe (optional)</li> <li>4. Defective Main Control PC Board (A1)</li> </ol>	<ol style="list-style-type: none"> <li>1. Disconnect wire # <b>24</b> from terminal E3 of the Gate Driver PC Board (A3). Restart the AT10.1. If you are able to measure dc output current, the SCR module (A16) is defective. Replace the entire rectifier assembly (A6).</li> <li>2. Remove one end of R4 from TB5 (on the back of the front panel). Repeat for R14 connected to TB1(-). Measure their values with an Ohmmeter. See the table in Section 3.6 for resistance values. If either resistor is not within 1% of the specified value, replace resistors (R4 or R15) as needed.</li> <li>3. Remove the leads from the probe and measure its resistance. At 77 °F / 25 °C the resistance should be about 10,000 Ω. If it is not, replace the probe assembly (A10).</li> <li>4. If the front panel meter displays more than 110% of the AT10.1 rated dc current, the Main Control PC Board (A1) may be defective. Disconnect wire # <b>24</b> from terminal E3 of the Gate Driver PC Board (A3). If the output current drops to zero (Adc), replace the Main Control PC Board (A1).</li> </ol>
Output voltage does not agree with front panel meter	<ol style="list-style-type: none"> <li>1. Temperature compensation probe is installed</li> <li>2. Components may have been replaced</li> <li>3. Defective or wrong value scaling resistor (R4 or R14)</li> <li>4. Defective Main Control PC Board (A1)</li> </ol>	<ol style="list-style-type: none"> <li>1. If the optional temperature compensation probe is installed, the output voltage may be different from the selected float or equalize voltage. See Section 1.11, Step 11. The difference in voltages depends on probe temperature. The front panel meter always displays the selected voltage as if the battery were at 77 °F / 25 °C.</li> <li>2. If the Main Control PC Board (A1), or any other electrical component, has recently been replaced, recalibrate the digital dc meter as described in Section 2.3.7.</li> <li>3. Remove one end of R4 from TB5 (on the back of the front panel). Repeat for R14 connected to TB1(-). Measure their values with an Ohmmeter. See the table in Section 3.6 for resistance values. If either resistor is not within 1% of the specified value, replace resistors (R4 or R15) as needed.</li> <li>4. Turn off (open) both front panel circuit breakers. Restart by turning on the dc breaker (CB2) <b>first</b>, followed by the ac breaker (CB1) second. If the AT10.1 still displays or outputs the wrong dc voltage, replace the Main Control PC Board (A1).</li> </ol>

## SERVICING THE AT10.1

SYMPTOM	PROBABLE CAUSE	RECOMMENDED ACTION
AT10.1 never reaches Foat or Equalize voltage (within 1%)	<ol style="list-style-type: none"> <li>1. Current Limit set too low</li> <li>2. Defective battery or dc load, or load is too great</li> <li>3. Wrong ac voltage, or Vac too low, or T1 mis-wired</li> <li>4. Defective SCR module (A16)</li> <li>5. Defective Main Control PC Board (A1)</li> </ol>	<ol style="list-style-type: none"> <li>1. If the AT10.1 is not in <b>Edit Mode</b>, press the <b>EDIT/ENTER</b> key six (6) times, until the meter display flashes the Current Limit value (in Amperes). If the Current Limit is less than 110%, adjust it up to 110% as described. See Section 2.3.5, <i>Setting the Current Limit Value</i>, for details.</li> <li>2. Check each cell of the battery. If one or more cells are shorted, the AT10.1 may not be able to reach the Float voltage. You may have the same problem if the normal dc load current is more than the rated output current of the AT10.1.</li> <li>3. Confirm the primary taps (T1-H#) are wired correctly for your input voltage. See Section 1.6, <i>Changing Transformer Taps</i>. The actual ac input voltage must be at least 88% of the rated value for the AT10.1 to produce full output power.</li> <li>4. Use a clamp-on ammeter to measure current in wires # <b>11</b> and # <b>12</b>, between the transformer (T1) and the Gate Driver PC Board (A3). If it less than 70% of the dc output current, the SCR module (A16) is defective. Replace the entire rectifier assembly (A6).</li> <li>5. Turn off (open) both front panel circuit breakers. Wait 60 seconds. Turn on the dc breaker (CB2) <b>first</b>, followed by the ac breaker (CB1) second. If the AT10.1 output is below the Current Limit value, but it still has the wrong output voltage, replace the Main Control PC Board (A1).</li> </ol>
Input current too high	<ol style="list-style-type: none"> <li>1. Wrong ac voltage, or Vac too low, or T1 mis-wired</li> <li>2. Defective SCR module (A16)</li> <li>3. Defective Transformer</li> </ol>	<ol style="list-style-type: none"> <li>1. Confirm the primary taps (T1-H#) are wired correctly for your input voltage. See Section 1.6, <i>Changing Transformer Taps</i>. The actual ac input voltage must be at least 88% of the rated value for the AT10.1 to produce full output power.</li> <li>2. Disconnect wire # <b>24</b> from terminal E3 of the Gate Driver PC Board (A3). Restart the AT10.1. If you are able to measure dc output current, the SCR module (A16) is defective. Replace the entire rectifier assembly (A6).</li> <li>3. Test by disconnecting secondary wires from T1-X1, T1-X4, T1-Y1 and T1-Y2. If ac input current is still too high, replace the main power transformer (T1).</li> </ol>
Output ripple voltage too high	<ol style="list-style-type: none"> <li>1. AT10.1 is UN-filtered</li> <li>2. Battery is disconnected or defective</li> <li>3. Battery too small for charger dc current rating</li> <li>4. One or more defective dc filter capacitors</li> </ol>	<ol style="list-style-type: none"> <li>1. Verify by comparing model number on data nameplate decal against the ordering code on the inside front cover of this manual. If necessary, order and install dc filter field kit.</li> <li>2. Confirm battery, which lowers ripple, is connected. Inspect battery according to the manufacturer's instructions.</li> <li>3. Measure ripple voltage on the dc output and compare the value against the specification for your AT10.1 model on page 70. The listed ripple rating is for a battery Ampere-hours rating which is four (4) times the charger Ampere rating. For a smaller battery, ripple may be higher.</li> <li>4. Shut down the AT10.1 and wait several minutes to allow capacitors to discharge. Open the AT10.1 and locate the blue cylindrical electrolytic filter caps. Test each with a capacitance meter. Replace dc filter capacitors (C1 and/or C2) as needed.</li> </ol>

## SERVICING THE AT10.1

SYMPTOM	PROBABLE CAUSE	RECOMMENDED ACTION
AT10.1 very noisy	<ol style="list-style-type: none"> <li>Loose hardware or enclosure panel</li> <li>Defective SCR module</li> </ol>	<ol style="list-style-type: none"> <li>Remove the AT10.1 enclosure shroud. Check and tighten all component mounting hardware. Replace the shroud, making sure all external hardware is secure.</li> <li>Use a clamp-on ammeter to measure the ac current in wires # 11 and # 12, between T1 and the rectifier. If it less than 70% of the dc output current, one of the SCRs or diodes is defective. Replace the entire rectifier assembly (A6).</li> </ol>
Meter readings are erratic	<ol style="list-style-type: none"> <li>Defective or disconnected battery</li> <li>Defective or wrong value scaling resistor (R4 or R14)</li> <li>Defective Main Control PC Board (A1)</li> </ol>	<ol style="list-style-type: none"> <li>Shut down the AT10.1. With a light dc load connected to the battery, confirm each cell reads the nominal cell voltage (2.0V for lead-acid or 1.25V for Ni-Cd). Restart the AT10.1. Each cell should now read the nominal Float voltage (2.2V for lead-acid or 1.35V for Ni-Cd).</li> <li>Remove one end of R4 from TB5 (on the back of the front panel). Repeat for R14 connected to TB1(-). Measure their values with an Ohmmeter. See the table in Section 3.6 for resistance values. If either resistor is not within 1% of the specified value, replace resistors (R4 and/or R15) as needed.</li> <li>If the measured dc output voltage is constant, but the front panel meter display reading is erratic, replace the Main Control PC Board (A1).</li> </ol>
Lamp Test key does not work, or some LEDs do not light	<ol style="list-style-type: none"> <li>No Vac</li> <li>Main Control PC Board (A1) is not secured to front panel</li> <li>Defective Main Control PC Board (A1)</li> </ol>	<ol style="list-style-type: none"> <li>The Lamp Test key does not work during ac power failure.</li> <li>Open the AT10.1 front panel door. Confirm the Main Control PC Board (A1) is securely mounted to the nylon standoffs. All indicators should extend about 0.125in / 3.2mm through the front of the panel.</li> <li>Press the <b>LAMP TEST</b> key. If some, but not all, of the indicators light, or the digital dc meter does not display "<b>8888</b>", replace the Main Control PC Board (A1).</li> </ol>
One or more front panel keys do not work	<ol style="list-style-type: none"> <li>Front panel is locked</li> <li>Main Control PC Board (A1) is not secured to front panel</li> <li>Defective Main Control PC Board (A1)</li> </ol>	<ol style="list-style-type: none"> <li>Open the front panel door. Confirm jumper (J9) on the Main Control PC Board (A1) is in the <b>ENABLE</b> position.</li> <li>Open the AT10.1 front panel door. Confirm the Main Control PC Board (A1) is securely, and evenly, mounted to the nylon standoffs. Front panel keys must operate freely.</li> <li>Turn off (open) both front panel circuit breakers. Turn on (close) the dc circuit breaker (CB2) <b>first</b>, followed by the ac circuit breaker (CB1) second. If some of the front panel keys still do not work, replace the Main Control PC Board (A1).</li> </ol>
Two AT10.1s connected in parallel, but only one has output current	<ol style="list-style-type: none"> <li>If the forced load sharing option is <b>not</b> supplied, check for normal operation of both AT10.1s</li> <li>FLS option (EJ5126-##)</li> </ol>	<ol style="list-style-type: none"> <li>Multiple AT10.1s are not designed to share load current, without the optional forced load sharing cable installed. When two (2) or more AT10.1s are connected in parallel without this option, it is normal for one of the units to have no dc output current. You can check the operation of the "off" AT10.1 by increasing its Float voltage until it starts to deliver dc output current. When you have finished the test, make sure both AT10.1s are set to the same Float and Equalize voltages.</li> <li>See <b>Appendix F</b> on page 90 for troubleshooting of the AT Series Forced Load Sharing feature.</li> </ol>

## SERVICING THE AT10.1

SYMPTOM	PROBABLE CAUSE	RECOMMENDED ACTION
<p><b>HIGH DC VOLTAGE</b> indicator is on</p>	<p>1. HVDC alarm and Equalize voltage settings are mismatched</p> <p>2. Defective SCR module</p> <p>3. Defective Main Control PC Board (A1)</p>	<p>1. Confirm the High DC Voltage alarm setting is <b>higher</b> than the Equalize voltage setting. See Sections 2.3.2 and 2.3.4 for details.</p> <p>2. Disconnect wire # <b>24</b> from terminal E3 of the Gate Driver PC Board (A3). Restart the AT10.1. If you are able to measure dc output current, the SCR module (A16) is defective. Replace the entire rectifier assembly (A6).</p> <p>3. Turn off (open) both front panel breakers. Turn on the dc breaker (CB2) <b>first</b>, followed by the ac breaker (CB1). If the AT10.1 output voltage is normal, but the <b>HIGH DC VOLTAGE</b> indicator is still on, replace the Main Control PC Board (A1).</p>
<p>No <b>alarm</b>, but output voltage is above High DC Voltage setting</p>	<p>1. Output current is below 2%</p> <p>2. Defective Main Control PC Board (A1)</p>	<p>1. The AT10.1 dc output current must be greater than 2% of rated value to produce a High DC Voltage alarm. See <b>Parallel Operation</b> passage in Section 2.3.6.</p> <p>2. Turn off (open) both front panel circuit breakers. Wait 60 seconds. Turn on the dc breaker (CB2) <b>first</b>, followed by the ac breaker (CB1) second. If the AT10.1 output voltage is above the alarm setting, but the <b>HIGH DC VOLTAGE</b> indicator still does not light, replace the Main Control PC Board (A1).</p>
<p><b>LOW DC VOLTAGE</b> indicator is on ac &amp; dc breakers are closed ac input voltage is normal dc output current is present</p>	<p>1. Battery is discharged</p> <p>2. Low DCV alarm and Float voltage settings are mismatched</p> <p>3. Defective SCR module</p> <p>4. Defective Main Control PC Board (A1)</p> <p>5. Defective dc output circuit breaker (CB2)</p>	<p>1. After an ac power failure, or battery discharge for any other reason, it may take several hours to recharge the battery. It is normal for the <b>LOW DC VOLTAGE</b> indicator to be on until the battery voltage is above the Low DC Voltage alarm setting.</p> <p>2. Make sure the Low DC Voltage alarm setting is <b>lower</b> than the Float voltage setting. See Sections 2.3.2 and 2.3.4 for details.</p> <p>3. Use a clamp-on ammeter to measure the ac current in wires # <b>11</b> and # <b>12</b>, between T1 and the rectifier. If it less than 70% of the dc output current, one of the SCRs or diodes is defective. Replace the entire rectifier assembly (A6).</p> <p>4. Turn off (open) both front panel circuit breakers. Restart by turning on the dc breaker (CB2) <b>first</b>, followed by the ac breaker (CB1) second. If the AT10.1 output voltage is normal, but the <b>LOW DC VOLTAGE</b> indicator is still on, replace the Main Control PC Board (A1).</p> <p>5. Shut down the AT10.1 and disconnect the battery. Connect a light dc load to the AT10.1 and turn on (close) the dc circuit breaker (CB2). Measure voltage between input and output terminal(s) of the dc breaker. It is normally no more than 50 millivolts. If it is near the rated dc output voltage of the AT10.1, replace the dc output circuit breaker (CB2).</p>

## SERVICING THE AT10.1

SYMPTOM	PROBABLE CAUSE	RECOMMENDED ACTION
<p><b>DC OUTPUT FAILURE</b> indicator is on ac &amp; dc breakers (CB1/CB2) are closed ac input voltage is normal</p>	<ol style="list-style-type: none"> <li>1. Defective SCR module</li> <li>2. Defective Main Control PC Board (A1)</li> <li>3. Defective transformer (T1)</li> <li>4. Defective dc output circuit breaker (CB2)</li> </ol>	<ol style="list-style-type: none"> <li>1. Use a clamp-on ammeter to measure the ac current in wires # 11 and # 12, between T1 and the rectifier. If it less than 70% of the dc output current, one of the SCRs or diodes is defective. Replace the entire rectifier assembly (A6).</li> <li>2. Turn off (open) both front panel circuit breakers. Restart by turning on the dc breaker (CB2) <i>first</i>, followed by the ac breaker (CB1) second. If the AT10.1 output voltage and current are normal, but the <b>DC OUTPUT FAILURE</b> indicator is still on, replace the Main Control PC Board (A1).</li> <li>3. Use an ac voltmeter to measure the <i>secondary</i> potential from T1-X1 to X4. It is normally 50% to 80% higher than the rated dc output voltage. If it is too low, check the <i>primary</i> tap wiring. See Section 1.6 for details. If the primary (T1-H#) voltage is 0 Vac, replace the main power transformer (T1).</li> <li>4. Shut down the AT10.1 and disconnect the battery. Connect a light dc load to the AT10.1 and turn on (close) the dc circuit breaker (CB2). Measure voltage between input and output terminal(s) of the breaker. It is normally no more than 50 milliVolts. If it is near the rated dc output voltage of the AT10.1, replace the dc output circuit breaker (CB2).</li> </ol>
<p><b>AC INPUT FAILURE</b> indicator is on</p>	<ol style="list-style-type: none"> <li>1. AC power failure</li> <li>2. Tripped upstream feed breaker / fuse</li> <li>3. Defective wiring</li> <li>4. Defective Main Control PC Board (A1)</li> </ol>	<ol style="list-style-type: none"> <li>1. If the ac input power fails, the front panel <b>AC ON</b> indicator goes out, and the <b>AC INPUT FAILURE</b> indicator goes on.</li> <li>2. Make sure the front panel ac input circuit breaker (CB1) is closed. Measure ac voltage at TB1-L1 to TB1-L2. If it is zero (Vac), check upstream ac distribution breakers and/or fuses.</li> <li>3. Measure ac voltage at the transformer primary taps (T1-H1 and T1-H5). It should be the same as the ac input supply voltage.</li> <li>4. Turn off (open) both front panel circuit breakers. Restart by turning on the dc breaker (CB2) <i>first</i>, followed by the ac breaker (CB1) second. If the <b>AC ON</b> and <b>AC INPUT FAILURE</b> indicators are <i>both</i> still on, replace the Main Control PC Board (A1).</li> </ol>

## SERVICING THE AT10.1

SYMPTOM	PROBABLE CAUSE	RECOMMENDED ACTION
<p><b>POS GND</b> or <b>NEG GND</b> indicator is on</p>	<p>1. External ground fault on dc bus</p> <p>2. DC output circuit breaker (CB2) is open and <b>POS GND</b> indicator is on</p> <p>3. Alarm needs calibration</p> <p>4. Defective internal charger wiring</p> <p>5. Defective Main Control PC Board (A1)</p> <p>6. Paralleled AT10.1s are shut down</p>	<p>1. The AT10.1 has detected a ground fault <b>external</b> to the charger. Shut down and disconnect the AT10.1 from the battery and dc bus. Check the battery and dc bus for a ground fault. See <b>Application Note (JD5032-00)</b> for assistance.</p> <p>2. If the AT10.1 has been placed into "standby" by opening the dc breaker (CB2), the ground detection circuit supplies an erroneous alarm. This is considered an <b>abnormal</b> condition for the AT10.1 and is not recommended. Close the dc breaker (CB2) and the alarm should end. To place the AT10.1 in "standby", open <b>both</b> front panel circuit breakers (CB1/CB2).</p> <p>3. Calibrate the AT10.1 ground fault detection sensitivity. See Section 2.3.4 for details.</p> <p>4. Turn off (open) both front panel circuit breakers. Disconnect the AT10.1 from the battery and dc bus. Restart the AT10.1. Measure voltage from TB1(+) to chassis, and then from TB1(-) to chassis. The voltage readings should be equal, each approximately half the total output voltage (Vdc). If there is more than a 10% imbalance, shut down the AT10.1. Inspect all wiring from TB1(+/-) to the dc circuit breaker (CB2), and from the rectifier (A16) to the dc filter inductor (L1). Look for evidence of insulation damage, wires run too close to metal edges, or insufficient spacing between terminals and chassis.</p> <p>5. Turn off (open) both front panel circuit breakers. Restart by turning on the dc breaker (CB2) <b>first</b>, followed by the ac breaker (CB1) second. If you are <b>sure</b> there is no ground fault on the external bus or within the AT10.1, but the <b>POS GND</b> or <b>NEG GND</b> indicator is still on, replace the Main Control PC Board (A1).</p> <p>6. Restart all other AT10.1s connected in parallel with unit that is experiencing ground fault alarm. Otherwise, disconnect and lock out from the dc bus all shut down AT10.1s.</p>
<p>Summary relay (TB3) is in alarm mode, but no front panel alarm indicator is on</p>	<p>1. Defective Main Control PC Board (A1)</p>	<p>1. Turn off (open) both front panel circuit breakers. Wait 60 seconds. Restart by turning on the dc breaker (CB2) <b>first</b>, followed by the ac breaker (CB1) second. If the summary relay remains in alarm mode, check the Low Level Detect indicator (DS10) on the Main Control PC Board (A1). See Section 2.3.8. If no other alarm is on, replace the Main Control PC Board (A1).</p>

# SERVICING THE AT10.1

---

## 3.5. REPLACING DEFECTIVE COMPONENTS

### WARNING

*High voltages appear at several points inside the AT10.1. Use extreme caution when working inside the enclosure. Do not attempt to work inside the AT10.1 unless you are a qualified technician or electrician. Disconnect and lock out all power from the AT10.1 before starting to remove or replace any components. Turn the ac power off at the distribution panel upstream from the charger. Disconnect the battery from the AT10.1 output terminals TB1(+/-).*

### NOTICE

While performing the following procedures, refer to the standard drawings in Appendix C for information on identifying internal components.

#### Removing the safety shield

Some of the repair procedures described below requires removal of the Plexiglas safety shield, mounted in front of the I/O panel. Unscrew the wing nuts and remove the washers to detach the shield. Do not lay the shield on the top of the AT10.1, The top vents are required for cooling.

### CAUTION

*Hazardous ac and dc voltages are present inside the AT10.1, on the I/O panel (TB1) terminals and certain internal components.*

#### Removing the enclosure shroud

You may need to remove the enclosure shroud in order to make some internal measurements, and to replace or repair components. Shut down and lock out all external power to the AT10.1. Disconnect the battery from the dc output terminals (TB1+/-).

Remove the eleven (11) screws that hold the shroud on the rear and bottom of the enclosure, then the two screws on the left side that hold the rectifier heat sink assembly. Support the front panel and lift the shroud straight up to remove it. Make sure to save the plastic washers from the door hinge.

The heat sink assembly is supported from the rear panel. Avoid putting any mechanical stress on the heat sink.

#### Replacing the enclosure shroud

Lower the shroud onto the enclosure base. Install and tighten the eleven (11) screws that hold the shroud on the rear and bottom of the base before you install the two screws that support the heat sink assembly on the left side wall. Remember to reinstall the plastic washers on the door hinge.



### Replacing the Main Control Printed Circuit Board (A1)

For details of this procedure, refer to *Service Instruction* ([JD5012-00](#)).

**NOTICE** *Printed circuit boards are sensitive to damage from static discharges. Leave replacement pc boards in their anti-static bags until you are ready to install them. Ground yourself before handling the board, by touching the ground stud on the back of the door. Always handle printed circuit boards by their edges.*

Shut down and lock out all power to the AT10.1. Disconnect the battery from the dc output terminals. Remove any optional user wiring from the various Main Control PCB (A1) terminals (e.g. TB3, TB8/J6, J3, etc.).

Remove the harness plug (J1) from the upper-left edge of the Main Control PC Board (A1), and unplug wire # **30** from the quick-connect terminal in the upper left corner of the board. The board is mounted on six (6) plastic standoffs. Compress the tab on each standoff, and pull the board toward you until it clears all standoffs.

Insert the replacement board onto the instrument panel with the same orientation, and push it onto the standoffs. Confirm the board is fully seated on all six (6) standoffs. Reconnect the harness plug (J1) to the A1 board at the upper-left edge. Replace wire # **30** on the quick-connect terminal. Replace user wiring to the various Main Control PC Board (A1) terminals (e.g. TB3, TB8/J6, J3, etc.). Restart the AT10.1 per Section 2.1.

**NOTICE** *Replacement Main Control Boards **MUST** be recalibrated.*

See Section 2.3.7 for adjusting the dc voltmeter accuracy. If the installation's parameters (float voltage, etc.) are different from the AT10.1 factory preset values, these values should re-entered per Section 2.3.

### Replacing the Rectifier Heat Sink Assembly (A6)

For details of this procedure, refer to *Service Instruction* ([JD5009-00](#)).

Shut down and lock out all power to the AT10.1. Remove the Plexiglas safety shield. Disconnect the battery from the dc output terminals. Check with a voltmeter before proceeding. Remove the enclosure shroud as described in the previous section. Make sure the rectifier heat sink has cooled, and remove the entire assembly by the front edge. Remove all wires attached to the rectifier pc board(s) as you pull the assembly out.

Hold the replacement Rectifier Assembly (A6) in front of the AT10.1 in the same orientation as the old. Reconnect all wires removed from the old rectifier as you insert it into the enclosure. To ensure correct replacement, refer to the standard drawings in Appendix C of this manual, or the service instruction supplied with the replacement assembly. Make sure all wires are connected to the proper terminals, and lugs are fully seated. If any lug does not fit snugly, disconnect it, tighten the ears, and reconnect.

## SERVICING THE AT10.1

---

Rotate the rectifier assembly into position in the enclosure. Line up the metal tab with the mounting hole on the back panel of the AT10.1 and slide the assembly into position. Replace the shroud as described in the previous section. Tighten all screws and restart the AT10.1.

### Replacing the optional dc filter assembly (A7)

The dc filter assembly consists of a diode heat sink, inductor L2, and one or two capacitors (C1x) installed on a single bracket.

Shut down and lock out all power to the AT10.1. Remove the Plexiglas safety shield. Disconnect the battery from the output terminals TB1(+/-).

Find the flying lead from the inductor L2 (wire # 50) and disconnect the other end from the center terminal of inductor L1 (at the upper right corner of the rear panel). Disconnect wire # 15 from the quick-connect terminal at the top center of the diode heat sink, and remove wire # 54 from terminal E7 on the front circuit board on the rectifier assembly.

Carefully note which terminal the wire is connected to. Remove the four (4) screws at the top of the dc filter bracket. The bracket and the inductor will both fall forward, away from the rear panel.

Lift the filter bracket up about 0.25in / 6.4mm to release it from the clips at the bottom of the bracket. Swing the filter assembly outward to the left, rotating it so that the heat sink comes out first and the capacitor(s) last.

Install the replacement filter assembly by inserting the capacitor end first, and rotating the assembly inward so that the heat sink is last to go in.

Push the bottom edge of the bracket into the clips in the rear panel, and install the four screws at the top of the bracket.

Connect wire # 15 to the quick-connect terminal at the top center of the diode heat sink. Route the flying lead from the inductor L2 (wire # 50) and connect it to the center terminal ("2") of the inductor L1. Reconnect wire # 54 to terminal E7 of the front circuit board on the rectifier assembly. Replace the shroud and the safety shield.

### Replacing the ac input or dc output circuit breaker (CB1, CB2)

Shut down and lock out all power to the AT10.1. Remove the Plexiglas safety shield. Disconnect the battery from the dc output terminals TB1(+/-). This includes remote sense wires if they were installed.

Check with a voltmeter before proceeding. Remove the two (2) circuit breaker mounting screws on the front panel. Carefully rotate the circuit breaker upward and pull it out of the enclosure. Remove wires from the terminals, one at a time, and transfer the wires to the terminals of the replacement breaker. ***Confirm all circuit breaker terminal screws are tight.*** Install the replacement breaker into the front panel, rotating it downward into place. Install the two (2) mounting screws.

### Replacing the main transformer (T1)

Shut down and lock out all power to the AT10.1. Remove the Plexiglas safety shield. Disconnect the battery from the output terminals TB1(+/-).

Check with a voltmeter before proceeding. This includes remote sense wires if they were installed. Remove the enclosure shroud and the safety shield. Disconnect the harness wires # 28 and # 29 from the upper row of transformer terminals. Disconnect wires # 11 and # 12 from the top of the rectifier heat sink. Disconnect harness wires # 3 and # 4 from the lower row of terminals. Leave both jumpers in place on the lower row.

Remove the four screws or nuts that secure the transformer to the rear panel. Support the transformer by the top of the core and lift it up to get the bottom bracket off the rear panel. Remove the transformer from the enclosure.

Check the jumpers on the bottom row of terminals of the replacement transformer. Make sure they are connected to the same terminals as the jumpers on the transformer you just removed from the AT10.1. For details see Section 1.6, *Changing the Transformer Taps*.

Hold the replacement transformer with the terminals labeled H1 through H5 at the bottom, facing you. Place the transformer against the rear panel, and slide the bottom of the transformer bracket into the slots on the rear panel. Install the four screws or nuts onto the mounting bracket of the transformer. Rewire the transformer, following the steps above in reverse. Refer to Section 1.6, and verify that the transformer is properly connected for your input voltage.

### Replacing the ac surge suppressors (VR2, VR4 or VR5)

Shut down and lock out all power to the AT10.1. Remove the Plexiglas safety shield. Disconnect the battery from the output terminals TB1(+/-).

For **VR2**, remove the hardware from the input terminal L1, and remove the lead of the ac surge suppressor. Install one lead of the replacement surge suppressor onto the L1 terminal. Replace the other wires and the hardware. Repeat procedure for the L2 terminal. Tighten all hardware.

For **VR4**, remove the hardware from the input terminal L1, and remove the lead of the ac surge suppressor. Install one lead of the replacement surge suppressor onto the L1 terminal. Replace the other wires and the hardware. Repeat procedure for the *left* ground stud. Tighten all hardware.

For **VR5**, repeat procedure for the ac surge suppressor connected to the L2 terminal and the *right* ground terminal. Tighten all hardware.

**NOTICE** *The ac surge suppressors are not polarized.*

## SERVICING THE AT10.1

---

### Replacing the dc surge suppressor (VR1)

Shut down and lock out all power to the AT10.1. Remove the Plexiglas safety shield. Disconnect the battery from the output terminals TB1(+/-).

Remove the hardware from the output terminal TB1(+), and remove the lead of the dc surge suppressor. Install one lead of the replacement surge suppressor. Replace the other wires and the hardware. Repeat for the output terminal TB1(-). Tighten all hardware.

**NOTICE** *The dc surge suppressor is not polarized.*

### Replacing the dc EMI filter networks (VR6/C4, VR7/C5)

Replace these networks as assemblies. Do not replace individual parts.

Shut down and lock out all power to the AT10.1. Remove the Plexiglas safety shield. Disconnect the battery from the output terminals TB1(+/-).

To replace the network VR6/C4, remove the hardware from the output terminal TB1(-), and remove the lead of the network. Cut the plastic wire ties holding the assembly tight against the I/O panel. Install one lead of the replacement network. Replace the other wires and the hardware. Repeat for the other lead of the network on the ground terminal. For the VR7/C5 network, use the above procedure, but start with the lead on TB1(+). Tighten all hardware. Replace cut wire ties if possible.

**NOTICE** *The dc EMI filter networks are not polarized.*

### Replacing the power supply ballast resistor (R3)

Shut down and remove all power to the AT10.1. Remove the Plexiglas safety shield. Disconnect the battery from the output terminals TB1(+/-).

Locate the power supply ballast resistor (R3) near the I/O panel (TB1). In 12 & 24 Vdc units, R3 is installed at the top right corner, connected to E17 and TB1(+). In 48 & 130 Vdc units, R3 is mounted on the bracket behind the I/O panel. In 130 Vdc 6A units, R3 is comprised of an assembly of two (2) resistors connected in series, mounted to the bracket.

Disconnect the lead of R3 connected to TB1(+) and replace it with the corresponding lead of the replacement power resistor. Remove the other lead of R3 from terminal E17 on the I/O panel and replace it with the remaining lead of the replacement power resistor. Tighten all hardware.

In 12 & 24 Vdc units, tuck the new R3 resistor behind the I/O panel so that leads are properly spaced. In 48 & 130 Vdc units, remove the screws that mount the old R3 resistor(s) to the bracket, and replace with the new resistor(s). Tighten all mounting hardware and restart the AT10.1.

For further information, refer to *Service Instruction* ([JD5010-00](#)).

### Replacing the positive scaling resistor (R4)

Locate the scaling resistor (R4) mounted to TB5 on the back of the front panel, just above the Main Control PC Board (A1). The resistor (R4 is the one on the left) is mounted on two quick-connect terminals. Remove the resistor by grasping the terminals by the plastic insulation, and pulling out and downward. Install the replacement resistor by pushing the terminals firmly onto the quick-connect blades on the terminal block (TB5).

### Replacing the voltage crowbar resistor (R6)

Locate the resistor (R6) mounted to TB5 on the back of the front panel, just above the Main Control PC Board (A1). The resistor (R6 is the one on the right) is mounted on two quick-connect terminals. Remove the resistor by grasping the terminals by the plastic insulation, and pulling out and downward. Install the replacement resistor by pushing the terminals firmly onto the quick-connect blades on the terminal block (TB5).

### Replacing the negative scaling resistor (R14)

Shut down and lock out all power to the AT10.1. Remove the Plexiglas safety shield. Disconnect the battery from the output terminals TB1(+/-). The scaling resistor R14 is connected to TB(-) with a ring lug. The other lead of the resistor is soldered to wire # **20**.

Remove the insulating sleeving from the soldered joint to wire # **20** (you may have to remove a harness tie) and cut the resistor lead near the solder joint. Disconnect the lugged-end of **R14** from TB1(-) and discard the old resistor.

Using a soldering iron no larger than 35 Watts, solder the bare lead of the new **R14** to wire # **20**. Insulate the joint with plastic electrical tape. Crimp a similar ring lug to the other lead of the new resistor. Connect the lugged end of the new scaling resistor **R14** to TB1(-).

# SERVICING THE AT10.1

## 3.6. ORDERING REPLACEMENT PARTS

All AT10.1 Series battery chargers ship with a supplemental **Parts Data Package** report, itemizing all components within the unit. Contact your sales representative to place an order for spare or replacement parts.

Please provide the following information for each component:

- Model number and serial number of your AT10.1 Series battery charger
- Reference Designator, factory part number and description
- Quantity required

### NOTICE

*Some of the factory part numbers listed on the **Parts Data Package** report may differ from the standard replacement part numbers listed in this manual. Custom parts may have replaced standard parts to satisfy your specification. In that case, you should order the part number(s) listed on the report.*

*The following table may specify part replacement **kits** that include other materials, such as installation instructions and packaging materials. You may order spare parts using either the report part number or listed kit. The factory may make necessary adjustments to your order to ensure proper delivery of a complete kit.*

Refer to the table below for the most common items.

**Table 3-1: REPLACEMENT PARTS**

Reference Designator	Description	Factory Part Number				Rec. Spare
		12 Vdc	24 Vdc	48 Vdc	130 Vdc	
A1	Main Control PC Board (EN5002-00)	EJ1243-10				Y
A3	Rectifier Gate Driver PC Board (EN5011-00)	EJ5093-00				
A5	Auxiliary Alarm Relay PCB (EN0027-00)	EJ1243-03				Y
A6	Rectifier / Heat Sink assembly (A3 + A16)	EJ1243-00				Y
A7	DC Output Filter assembly (standard)	see Table 3-2				
A8	Battery Eliminator Filter assembly (requires filtered AT10.1)	6Adc		EJ1155-01		
		12-25Adc		EJ1155-02		
A10	Temperature Compensation Probe assembly	see Appendix B, Table 2				
A16	Rectifier SCR Module	RM5003-06				
C1	DC Output Filter Capacitor	RP0019-09		RP0019-08		Y
C2	Battery Eliminator Filter Capacitor	RP0019-09		RP0019-08		Y
C4	EMI Filter Capacitor	see VR6/C4				
C5	EMI Filter Capacitor	see VR7/C5				
CB1	AC Breaker (standard) 120/208/240 Vac	see Table 3-3				
CB1	AC Breaker (medium AIC) 120/208/240 Vac	see Table 3-4				
CB1	AC Breaker (high AIC) 120/208/240 Vac	see Table 3-5				
CB1	AC Circuit Breaker (standard) 480 Vac	see Table 3-15				
CB1	AC Circuit Breaker (medium AIC) 480 Vac	RE0171-00				
CB1	AC Circuit Breaker (high AIC) 480 Vac	RE0043-00				
CB2	DC Circuit Breaker (standard)	see Table 3-6				
CB2	DC Circuit Breaker (medium AIC)	see Table 3-7				
CB2	DC Circuit Breaker (high AIC)	see Table 3-8				

# SERVICING THE AT10.1

Reference Designator	Description	Factory Part Number				Rec. Spare
		12 Vdc	24 Vdc	48 Vdc	130 Vdc	
<b>CR1</b>	Polarity Diode (RK0014-06)	EJ1243-04				Y
<b>CR2</b>	Blocking Diode (RK0014-06)	EJ1243-05				
<b>F1</b>	480 Vac M/H AIC AC Input Fuse	see Table 3-14				Y
<b>L1</b>	Main Inductor	see Table 3-9				
<b>L2</b>	DC Filter Inductor	see Table 3-13				
<b>P5</b>	Jumper for disabling Ground Detection circuit	RC0100-00				
<b>P7</b>	Jumper for voltage selection on A5 pc board	RC0100-00				
<b>P9</b>	Jumper for front panel lockout feature on A1	RC0100-00				
<b>R2</b>	Rating resistor	see Table 3-10				
<b>R3</b>	Power Supply (Ballast) Resistor	EJ1127-00 12 Ω 2W	EJ1127-01 68 Ω 11W	EJ1127-02 150 Ω 50W	EJ1127-03/23 (Note 1)	Y
<b>R4</b>	Scaling resistor (positive side)	EJ1134-00 3160 Ω	EJ1134-01 6980 Ω	EJ1134-02 14.0 kΩ	EJ1134-03 38.3 kΩ	
<b>R6</b>	Voltage crowbar resistor	EJ1135-00	EJ1135-01	EJ1135-02	EJ1135-03	
<b>R9</b>	Filter capacitor (C1) bleed resistor	EJ1137-00	EJ1137-00	EJ1137-01	EJ1137-02	
<b>R14</b>	Scaling resistor (negative side)	EJ1222-00 3160 Ω	EJ1222-01 6980 Ω	EJ1222-02 14.0 kΩ	EJ1222-03 38.3 kΩ	
<b>T1</b>	Main transformer (120/208/240 Vac)	see Table 3-11				
<b>T1</b>	Main transformer (480 Vac)	see Table 3-12				
<b>TB1-x</b>	I/O terminal box lug for #14-6 AWG	RC0056-04				
<b>VR1</b>	Output Surge Suppressor	EJ1132-01				Y
<b>VR2</b>	Input Surge Suppressor (120/208/240 Vac)	EJ1132-01				Y
<b>VR2</b>	Input Surge Suppressor (480 Vac)	EJ1132-02				Y
<b>VR3</b>	Input Lightning Arrestor	EJ1074-00				
<b>VR4/5</b>	Input Surge Suppressor (120/208/240 Vac)	EJ1132-01				Y
<b>VR4/5</b>	Input Surge Suppressor (480 Vac)	EJ1132-02				Y
<b>VR6/C4</b>	DC EMI Filter Network	EJ5021-01				
<b>VR7/C5</b>	DC EMI Filter Network	EJ5021-01				

**Note 1:** In 130 Vdc AT10.1 Group I units, two (2) different Power Supply (Ballast) Resistor assemblies (R3) are used, mounted behind the I/O panel (TB1):

- a) 12-25 Adc - **EJ1127-03** consists of one (1) 500 Ω 100W resistor
- b) 6 Adc - **EJ1127-23** consists of two (2) 250 Ω 50W resistors connected in series

**Note 2:** Listed part numbers subject to change without notice. Refer to data listed in AT10.1 Parts Data Package report for specific parts featured in a configured product.

# SERVICING THE AT10.1

---

Table 3-2: DC FILTER ASSEMBLIES (L2/C1/R9/CR1/CR2)

Current Rating	12 Vdc	24 Vdc	48 Vdc	130 Vdc
6 Adc	EJ1072-00	EJ1072-00	EJ1072-02	EJ1072-03
12 Adc	EJ1072-00	EJ1072-00	EJ1072-02	EJ1072-06
16 Adc	EJ1072-01	EJ1072-01	EJ1072-07	EJ1072-04
20 Adc	EJ1072-01	EJ1072-01	EJ1072-07	EJ1072-04
25 Adc	EJ1072-01	EJ1072-01	EJ1072-07	EJ1072-05

Table 3-3: STANDARD AC CIRCUIT BREAKERS (CB1) - 120/208/240 Vac

Current Rating	12 Vdc	24 Vdc	48 Vdc	130 Vdc
6 Adc	RE0159-11	RE0159-11	RE0159-11	RE0159-13
12 Adc	RE0159-11	RE0159-11	RE0159-13	RE0159-16
16 Adc	RE0159-11	RE0159-12	RE0159-13	RE0159-19
20 Adc	RE0159-11	RE0159-12	RE0159-14	RE0159-20
25 Adc	RE0159-11	RE0159-12	RE0159-15	RE0159-20

Table 3-4: MEDIUM INTERRUPTING CAPACITY AC BREAKERS (CB1) - 120/208/240 Vac

Current Rating	12 Vdc	24 Vdc	48 Vdc	130 Vdc
6 Adc	RE0171-00	RE0171-00	RE0171-00	RE0171-01
12 Adc	RE0171-00	RE0171-00	RE0171-01	RE0171-04
16 Adc	RE0171-00	RE0171-00	RE0171-01	RE0171-07
20 Adc	RE0171-00	RE0171-00	RE0171-02	RE0171-08
25 Adc	RE0171-00	RE0171-00	RE0171-03	RE0171-08

Table 3-5: HIGH INTERRUPTING CAPACITY AC BREAKERS (CB1) - 120/208/240 Vac

Current Rating	12 Vdc	24 Vdc	48 Vdc	130 Vdc
6 Adc	RE0043-00	RE0043-00	RE0043-00	RE0043-01
12 Adc	RE0043-00	RE0043-00	RE0043-01	RE0043-04
16 Adc	RE0043-00	RE0043-00	RE0043-01	RE0043-07
20 Adc	RE0043-00	RE0043-00	RE0043-02	RE0043-08
25 Adc	RE0043-00	RE0043-00	RE0043-03	RE0043-08



# SERVICING THE AT10.1

**Table 3-6: STANDARD DC CIRCUIT BREAKERS (CB2)**

<b>Current Rating</b>	<b>12 Vdc</b>	<b>24 Vdc</b>	<b>48 Vdc</b>	<b>130 Vdc</b>
<b>6 Adc</b>	RE0159-01	RE0159-01	RE0159-01	RE0159-12
<b>12 Adc</b>	RE0159-02	RE0159-02	RE0159-02	RE0159-13
<b>16 Adc</b>	RE0159-03	RE0159-03	RE0159-03	RE0159-14
<b>20 Adc</b>	RE0159-04	RE0159-04	RE0159-04	RE0159-15
<b>25 Adc</b>	RE0159-06	RE0159-06	RE0159-06	RE0159-17

**Table 3-7: MEDIUM AMPERE INTERRUPTING CAPACITY DC CIRCUIT BREAKERS (CB2)**

<b>Current Rating</b>	<b>12 Vdc</b>	<b>24 Vdc</b>	<b>48 Vdc</b>	<b>130 Vdc</b>
<b>6 Adc</b>	RE0171-00	RE0171-00	RE0171-00	RE0171-00
<b>12 Adc</b>	RE0171-01	RE0171-01	RE0171-01	RE0171-01
<b>16 Adc</b>	RE0171-02	RE0171-02	RE0171-02	RE0171-02
<b>20 Adc</b>	RE0171-03	RE0171-03	RE0171-03	RE0171-03
<b>25 Adc</b>	RE0171-04	RE0171-04	RE0171-04	RE0171-04

**Table 3-8: HIGH AMPERE INTERRUPTING CAPACITY DC CIRCUIT BREAKERS (CB2)**

<b>Current Rating</b>	<b>12 Vdc</b>	<b>24 Vdc</b>	<b>48 Vdc</b>	<b>130 Vdc</b>
<b>6 Adc</b>	RE0043-00	RE0043-00	RE0043-00	RE0043-00
<b>12 Adc</b>	RE0043-01	RE0043-01	RE0043-01	RE0043-01
<b>16 Adc</b>	RE0043-02	RE0043-02	RE0043-02	RE0043-02
<b>20 Adc</b>	RE0043-03	RE0043-03	RE0043-03	RE0043-03
<b>25 Adc</b>	RE0043-04	RE0043-04	RE0043-04	RE0043-04

**Table 3-9: MAIN INDUCTOR (L1)**

<b>Current Rating</b>	<b>12 Vdc</b>	<b>24 Vdc</b>	<b>48 Vdc</b>	<b>130 Vdc</b>
<b>6 Adc</b>	AP0928-00	AP0928-00	AP0928-00	AP1122-00
<b>12 Adc</b>	AP0928-00	AP0928-00	AP0928-00	AP0930-00
<b>16 Adc</b>	AP0926-00	AP0926-00	AP0926-00	AP0931-00
<b>20 Adc</b>	AP0926-00	AP0926-00	AP0926-00	AP0931-00
<b>25 Adc</b>	AP0926-00	AP0926-00	AP0926-00	AP0931-00

**NOTE:** Listed part numbers subject to change without notice. Refer to data listed in AT10.1 Parts Data Package report.

# SERVICING THE AT10.1

---

Table 3-10: RATING RESISTOR (R2)

Current Rating	12 Vdc	24 Vdc	48 Vdc	130 Vdc
<b>6 Adc</b>	EJ1133-00 34.8 kΩ	EJ1133-05 13.0 kΩ	EJ1133-10 5.11 kΩ	EJ1133-15 1.50 kΩ
<b>12 Adc</b>	EJ1133-01 40.2 kΩ	EJ1133-06 15.4 kΩ	EJ1133-11 6.19 kΩ	EJ1133-16 2.21 kΩ
<b>16 Adc</b>	EJ1133-02 53.6 kΩ	EJ1133-07 19.6 kΩ	EJ1133-12 7.50 kΩ	EJ1133-17 2.74 kΩ
<b>20 Adc</b>	EJ1133-03 78.7 kΩ	EJ1133-08 23.7 kΩ	EJ1133-13 9.09 kΩ	EJ1133-18 3.57 kΩ
<b>25 Adc</b>	EJ1133-04 118 kΩ	EJ1133-09 29.4 kΩ	EJ1133-14 11.0 kΩ	EJ1133-19 4.32 kΩ

Connector terminal extraction tool: RC0124-71 (*Molex p/n: 11-03-0044*)

Table 3-11: MAIN TRANSFORMER (T1) - 120/208/240 Vac

Current Rating	12 Vdc	24 Vdc	48 Vdc	130 Vdc
<b>6 Adc</b>	AA0718-00	AA0719-00	AB2023-00	AB1868-00
<b>12 Adc</b>	AA0718-00	AA0719-00	AB2023-00	AB1857-00
<b>16 Adc</b>	AA0720-00	AB1855-00	AB1856-00	AB1858-00
<b>20 Adc</b>	AA0720-00	AB1855-00	AB1856-00	AB1858-00
<b>25 Adc</b>	AA0720-00	AB1855-00	AB1856-00	AB1858-00

Table 3-12: MAIN TRANSFORMER (T1) - 480 Vac

Current Rating	12 Vdc	24 Vdc	48 Vdc	130 Vdc
<b>6 Adc</b>	AA0733-00	AA0734-00	AB2038-00	AB2039-00
<b>12 Adc</b>	AA0733-00	AA0734-00	AB2038-00	AB2032-00
<b>16 Adc</b>	AA0735-00	AB2035-00	AB2036-00	AB2037-00
<b>20 Adc</b>	AA0735-00	AB2035-00	AB2036-00	AB2037-00
<b>25 Adc</b>	AA0735-00	AB2035-00	AB2036-00	AB2037-00

## SERVICING THE AT10.1

Table 3-13: FILTER INDUCTOR (L2)

Current Rating	12 Vdc	24 Vdc	48 Vdc	130 Vdc
<b>6 Adc</b>	AP0928-00	AP0928-00	AP0928-00	AP1081-00
<b>12 Adc</b>	AP0928-00	AP0928-00	AP0928-00	AP0928-00
<b>16 Adc</b>	AP0927-00	AP0927-00	AP0926-00	AP0926-00
<b>20 Adc</b>	AP0927-00	AP0927-00	AP0926-00	AP0926-00
<b>25 Adc</b>	AP0927-00	AP0927-00	AP0926-00	AP0926-00

Table 3-14: 480 Vac INPUT FUSE (F1) - MED/HIGH AIC BREAKERS

Current Rating	12 Vdc	24 Vdc	48 Vdc	130 Vdc
<b>6A</b>	RE0008-00	RE0008-00	RE0008-02	RE0008-06
<b>12A</b>	RE0008-00	RE0008-02	RE0008-06	RE0008-08
<b>16A</b>	RE0008-02	RE0008-06	RE0008-08	RE0008-09
<b>20A</b>	RE0008-02	RE0008-06	RE0008-08	RE0008-11
<b>25A</b>	RE0008-02	RE0008-06	RE0008-08	RE0008-11

Table 3-15: STANDARD AC CIRCUIT BREAKERS (CB1) - 480 Vac

Current Rating	12 Vdc	24 Vdc	48 Vdc	130 Vdc
<b>6 Adc</b>	RE5002-03	RE5002-04	RE5002-05	RE5002-06
<b>12 Adc</b>	RE5002-03	RE5002-04	RE5002-06	RE5002-16
<b>16 Adc</b>	RE5002-03	RE5002-05	RE5002-07	RE5002-16
<b>20 Adc</b>	RE5002-04	RE5002-06	RE5002-07	RE5002-10
<b>25 Adc</b>	RE5002-05	RE5002-06	RE5002-08	RE5002-10

**NOTE:** Listed part numbers subject to change without notice. Refer to data listed in AT10.1 Parts Data Package report.

# APPENDIX A

## SPECIFICATIONS

Except as noted, all specifications apply at:  
77 °F / 25 °C, nominal ac line voltage & nominal float voltage

Specification	Conditions	12 Vdc	24 Vdc	48 Vdc	130 Vdc
Output voltage regulation	Vac +10%, -12% 0 to 100% load Frequency 60 ± 3 Hz (0 to 122 °F / -18 to 50 °C)	± 0.25% (see product literature for specific data)			
Transient response	20-100% load change, with battery connected	output voltage change ± 4% maximum recovery to ± 2.0% in 200 ms recovery to ± 0.5% in 500 ms			
Efficiency	12 Adc rating, full load (%)	67.00	72.00	78.00	85.00
	25 Adc rating, full load (%)	73.00	77.00	85.00	91.00
Output ripple voltage (per NEMA PE5-1996)	Unfiltered (with battery)	1% rms (typ.) at battery terminals			2% rms
	Filtered (with battery)	30 mV rms (max.) at battery terminals			100 mV
	Filtered (without battery)	1% rms (typ.)			2% rms
	Battery Eliminator Filter Option (without battery)	30 mV rms			100 mV
Current Limit	adjustable	50-110 % of rated output current			
Soft start	0 to 100% load	4 seconds			
Voltage adjustment ranges	Float (Vdc)	11.0-14.5	22.0-29.5	44.0-58.0	110-141
	Equalize (Vdc)	11.7-16.0	23.4-32.0	46.8-61.0	117-149
	High DC Voltage alarm (Vdc)	12-19	24-38	48-76	120-175
	Low DC Voltage alarm (Vdc)	7-14.5	15-29.5	30-58	80-141
Voltmeter range (Vdc)		0 - 21	0 - 42	0 - 75	0 - 195
Ammeter range (Adc)	all ratings	0 - 30			
Surge withstand capability	test per <b>ANSI C37.90.1-1989</b>	no erroneous outputs			
Reverse current from battery	ac input power failure	90 mA maximum			
Audible noise	average for four (4) sides, 5ft / 1.5m from enclosure	less than 65 dBA			
Cooling		natural convection			
Ambient temperature	operating	0 to 122 °F / -18 to 50 °C			
Elevation		3000ft / 1000m without de-rating			
Relative humidity		0 to 95% non-condensing			
Alarm relay contact rating	120 Vac / 125 Vdc	0.5 A resistive			

## FIELD INSTALLABLE ACCESSORIES AND OPTIONS

All options and accessories listed below are available in kits for field installation. Kits contain all parts and hardware with detailed installation instructions. To order accessories/options, please provide the following information for each kit:

- Model number, enclosure style, and serial number of your AT10.1
- Factory part number and description, from the table below
- Quantity required

Contact your sales representative to place an order for options & accessories.

Description	Kit Part Number
Standard DC Output Filtering (per NEMA PE5-1996)	see table 3-2
Battery Eliminator Filtering (per NEMA PE5-1996)	see table 3-1
Auxiliary Alarm Relay PC Board (A5) for standard circuit breakers	EI0213-00
Auxiliary Alarm Relay PC Board (A5) for med/high AIC circuit breakers	EI0213-01
Copper Ground Bus with one (1) CU-AL box lug for #14-6 AWG	EI0195-00
AC Input Lightning Arrestor (VR3) option	EJ1074-00
Floor-Mounting Kit for Style-586/594 Enclosure	EI0192-00
Relay Rack-Mounting Kit for Style-586/594 Enclosure	EI0193-00
NEMA Type 2 Drip Shield for Style-586/594 Enclosure	EI0191-00
NEMA Type 4 (12/13) Type Cabinet for Style-586/594 Enclosure	EI0214-0#
Cabinet Heater Assembly for Style-586/594 Enclosure	EJ1223-00
Padlock for Style-586/594 Enclosure Front Panel Door	EI0215-00
Remote Temperature Compensation Probe Assembly (A10)	see below
DNP3 Level 2 / Modbus Communications Module	see Appendix E
Forced Load Sharing Accessory	EJ5126-##

### Remote Temperature Compensation Probe

Full Option Part Number (includes cable & probe)	Cable Length	Replacement Cable Part Number
EJ5033-00	25ft / 7.6m	EJ5011-00
EJ5033-01	50ft / 15.2m	EJ5011-01
EJ5033-02	100ft / 30.5m	EJ5011-02
EJ5033-03	200ft / 61.0m	EJ5011-03

The remote battery temperature compensation option is supplied as a bagged kit, consisting of a single probe and user-specified cable. Also supplied are **Installation Instructions** for the option and a special **Application Note**, see Section 1.11.

1. Use a single cable assembly. Do not try to splice cables together to increase the length. If you need a longer cable, order a replacement from the table above.
2. To order a replacement probe (or puck), request part number EJ5032-00. This probe (A10) is good for all AT10.1 output voltages and all battery types.

# APPENDIX C

## Outline: AT10.1 Group I Battery Charger NEMA-1 Style-586 Enclosure (JE5023-03)

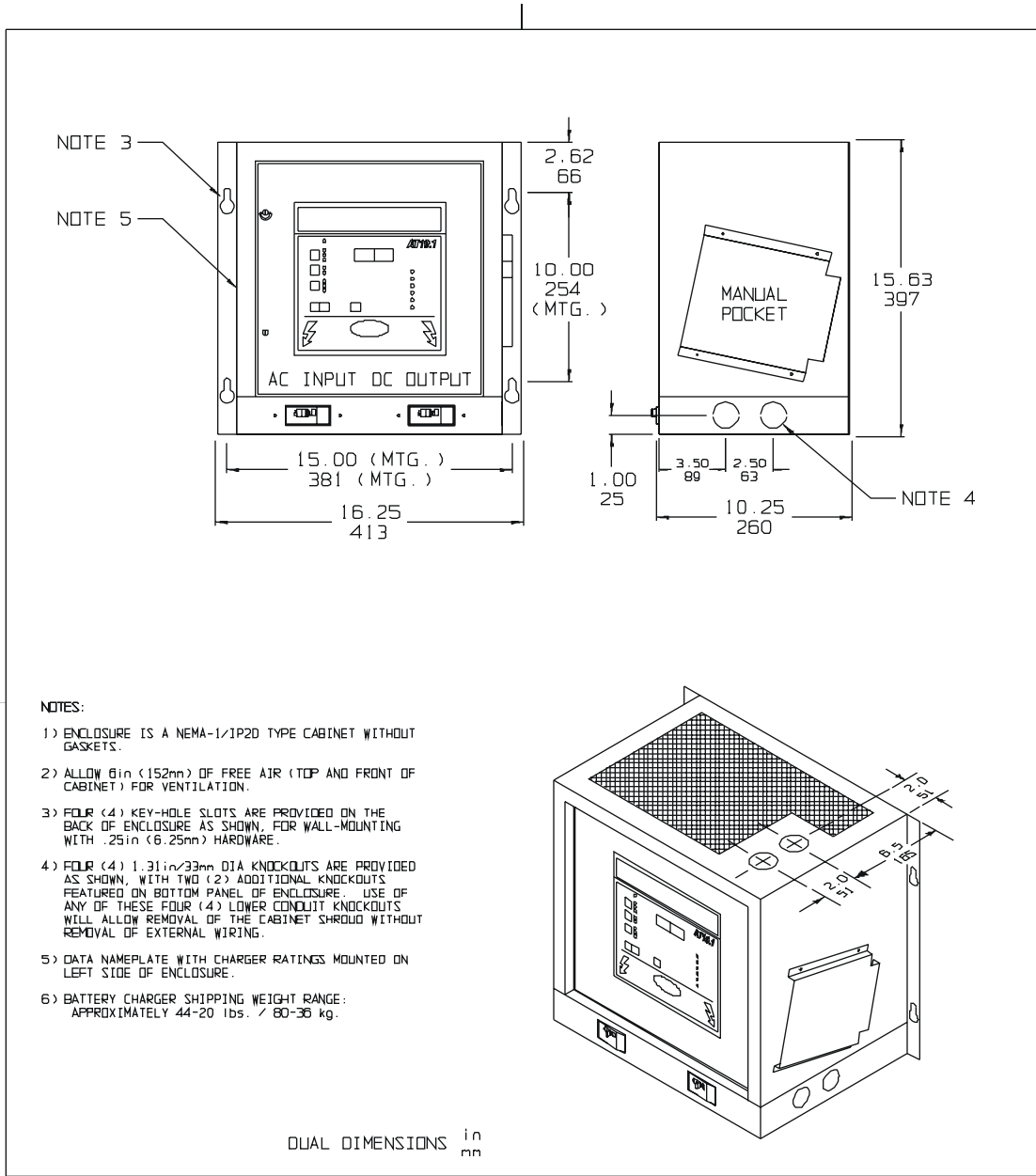

				THIRD ANGLE PROJECTION										
				DRAWN BY MCR		012304		TITLE AT10.1 SERIES BATTERY CHARGER OUTLINE : NEMA-1 STYLE-586 ENCLOSURE						
				APPROVED				DRAWING No		JE5023-03		REV	0	<b>A</b>
0	E1542	012304		UNLESS OTHERWISE NOTED DIMENSIONS ARE IN INCHES. TOLERANCES ARE:										
REV	ECN No	DATE	APP	SCALE	NTS	PART No	JE5023-03	SHEET	1	OF	1			

FILENAME [JE5023-03.PRT]

<http://www.ATSeries.net/PDFs/JE5023-03.pdf>

# APPENDIX C

## Optional Enclosure Dimensions: AT10.1 Group I Battery Charger w/Penthouse and Drip Shield - Style-586 Enclosure

		DIMENSION		in	mm
	Standard	WW	16.25	495	
		DD	12.50	324	
		HH	15.63	457	
		W	16.25	495	
		D	10.75	337	
	with Penthouse	WW	14.00	356	
		DD	10.75	337	
		HH	22.63	572	
		W	16.25	495	
		D	10.00	324	
	with Drip Shield	WW	18.75	559	
		DD	12.50	318	
		HH	19.50	552	
		W	16.25	495	
		D	10.75	337	
	with Penthouse & Drip Shield	WW	18.75	476	
		DD	12.50	337	
		HH	26.50	729	
		W	16.25	495	
		D	10.00	324	

# APPENDIX C

## Outline: AT10.1 Group I Battery Charger NEMA-1 Style-594 Enclosure (JE5024-03)

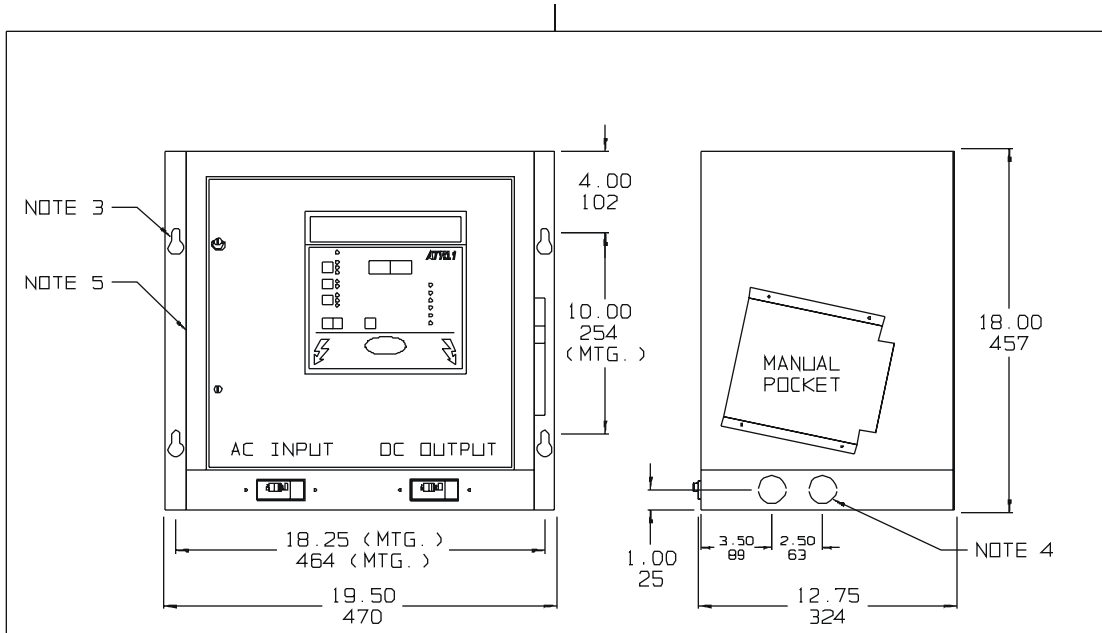

**NOTES:**

- 1) ENCLOSURE IS A NEMA-1/IP20 TYPE CABINET WITHOUT GASKETS.
- 2) ALLOW 6in (152mm) OF FREE AIR (TOP AND FRONT OF CABINET) FOR VENTILATION.
- 3) FOUR (4) KEY-HOLE SLOTS ARE PROVIDED ON THE BACK OF ENCLOSURE AS SHOWN, FOR WALL-MOUNTING WITH .25in (6.25mm) HARDWARE.
- 4) FOUR (4) 1.31in/33mm DIA KNOCKOUTS ARE PROVIDED AS SHOWN, WITH TWO (2) ADDITIONAL KNOCKOUTS FEATURED ON BOTTOM PANEL OF ENCLOSURE. USE OF ANY OF THESE FOUR (4) LOWER CONDUIT KNOCKOUTS WILL ALLOW REMOVAL OF THE CABINET SHROUD WITHOUT REMOVAL OF EXTERNAL WIRING.
- 5) DATA NAMEPLATE WITH CHARGER RATINGS MOUNTED ON LEFT SIDE OF ENCLOSURE.
- 6) BATTERY CHARGER SHIPPING WEIGHT RANGE: APPROXIMATELY 110-193 lbs. / 50-88 kg.

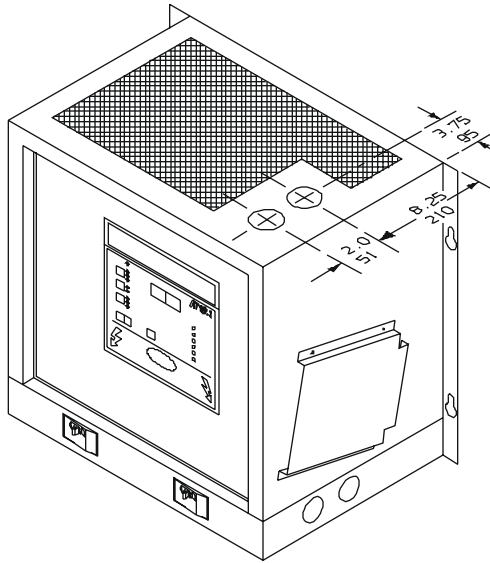

DUAL DIMENSIONS in mm

				THIRD ANGLE PROJECTION											
				DRAWN BY MCR		012304		TITLE AT10.1 SERIES BATTERY CHARGER OUTLINE: NEMA-1 STYLE-594 ENCLOSURE							
				APPROVED				DRAWING No		JE5024-03		REV	0	<b>A</b>	
0	E1542	012304		UNLESS OTHERWISE NOTED DIMENSIONS ARE IN INCHES. TOLERANCES ARE:				SCALE	NTS	PART No	JE5024-03	SHEET	1	OF	1

FILENAME [JE5024-03.PRT]

<http://www.ATSeries.net/PDFs/JE5024-03.pdf>



# APPENDIX C

## Optional Enclosure Dimensions: AT10.1 Group I Battery Charger w/Penthouse and Drip Shield - Style-594 Enclosure

			DIMENSION		in	mm
	Standard					
	WW	19.50	495			
	DD	12.75	324			
	HH	18.00	457			
	W	19.50	495			
	D	13.25	337			
	with Penthouse					
	WW	14.00	356			
	DD	13.25	337			
	HH	25.00	635			
	W	19.50	495			
	D	12.75	324			
	with Drip Shield					
	WW	22.00	559			
	DD	12.50	318			
	HH	21.75	552			
	W	19.50	495			
	D	13.25	337			
	with Penthouse & Drip Shield					
	WW	18.75	476			
	DD	13.25	337			
	HH	28.75	729			
	W	19.50	495			
	D	12.75	324			

# APPENDIX C

## Internal Component Layout: AT10.1 Group I Battery Charger Style-586/594 Enclosure w/Common Options (JE5027-99)

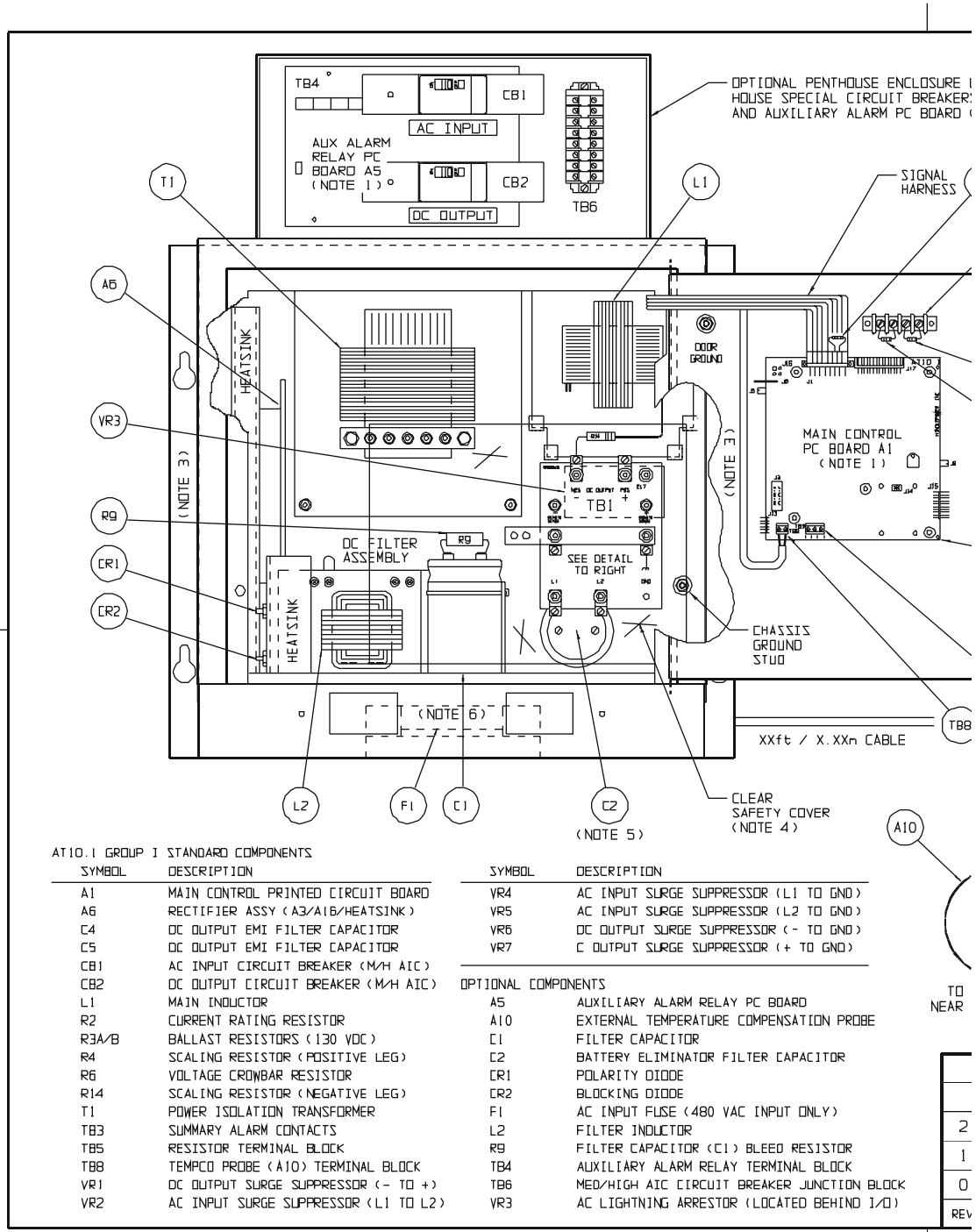

**NOTICE** This internal component layout drawing (JE5027-99) depicts an AT10.1 Series battery charger housed in a Style-586 or Style-594 enclosure, with ALL available options. Standard components (A1 through VR7) are supplied in all such units. Optional components (A5 through VR3) are supplied only in those AT10.1s configured with such options.

ENCLOSURE USED TO  
JIT BREAKERS (NOTE 6)  
1 PC BOARD (A5)

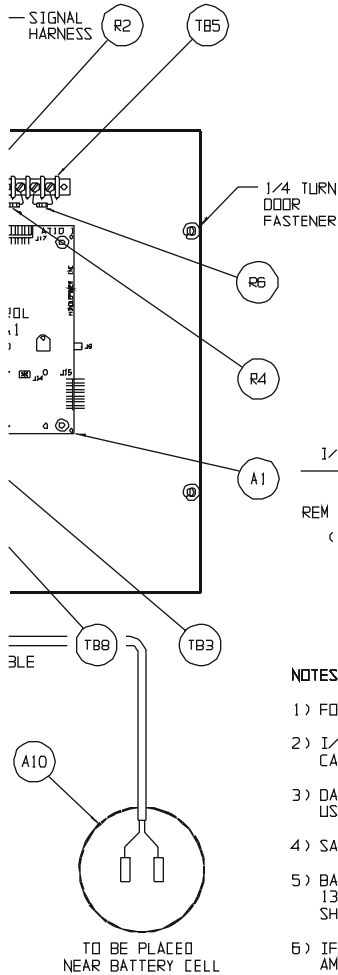

STYLE-586/594  
INPUT-OUTPUT  
TERMINAL BOARD  
TBI DETAIL  
(NOTE 2)

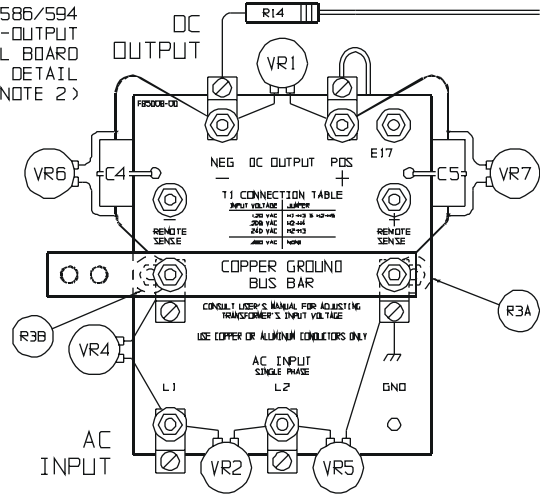

I/O TERMINAL	DESCRIPTION - TYPE	CONNECTION
TB1(+/-)	POS-NEG OUTPUT TERMINALS - CU-ALUMINUM COMPRESSION LUG	#14-6 AWG.
REM SENSE(+/-)	POS-NEG REMOTE SENSE TERMINALS - 10-32 SCREW HARDWARE	#10 RING LUG
(2) TB1-GND	GROUND TERMINAL - CU-ALUMINUM COMPRESSION LUG	#14-6 AWG.
TB1-L1/L2	AC INPUT TERMINALS - CU-ALUMINUM COMPRESSION LUG	#14-6 AWG.
TB3	SUMMARY ALARM TERMINAL BLOCK - SOLDERLESS COMPRESSION	#22-14 AWG.
TB4	AUXILIARY ALARM TERM BLOCK - SOLDERLESS COMPRESSION	#22-14 AWG.
TB8	TEMPCO PROBE (A10) INTERCONNECTION TERMINAL BLOCK	#22-14 AWG.

**NOTES:**

- 1) FOR DETAIL VIEWS OF ALL PC BOARDS (A1, A5, etc.) SEE DRAWING JE5030-19.
- 2) I/O PANEL PROTECTION (SHOWN ONLY ON DETAIL) CONSISTS OF EMI FILTER CAPACITORS (C4 & C5) AND SURGE SUPPRESSORS (VR1, VR2, VR4, VR5, VR6 & VR7).
- 3) DATA NAMEPLATE IS LOCATED ON EXTERIOR LEFT SIDE WALL OF ENCLOSURE. USER'S MANUAL POCKET IS LOCATED ON EXTERIOR RIGHT SIDE WALL OF ENCLOSURE.
- 4) SAFETY COVER DISPLAYS COMPONENT LAYOUT DIAGRAM, SCHEMATIC & INSTALLATION NOTES.
- 5) BATTERY ELIMINATOR FILTER CAPACITOR (C2) IS NORMALLY LOCATED IN FRONT OF C1. 130VDC-12ADC THRU 130VDC-25ADC UNITS UTILIZE TWO (2) C1s, THEREFORE C2 IS SHIFTED TO LOWER RIGHT-HAND CORNER OF ENCLOSURE AS SHOWN.
- 6) IF AT10.1 HAS 480VAC INPUT, OR IS CUSTOMER-SPECIFIED WITH MEDIUM/HIGH AMPERE INTERRUPTING CAPACITY CIRCUIT BREAKERS, CB1 AND CB2 ARE RELOCATED TO PENTHOUSE ENCLOSURE, AND TB6 IS ADDED.

REV	ECN No	DATE	APP	THIRD ANGLE PROJECTION	DRAWING No	REV	SHEET	OF
2	E2029	042805		DRAWN BY MCR	022703		2	B
1	E1742	091004	GRB	APPROVED	022803			
0	E1154	022703		UNLESS OTHERWISE NOTED DIMENSIONS ARE IN INCHES. TOLERANCES ARE:	JE5027-99		1	1
					SCALE NTS	PART No JE5027-99		

<http://www.ATSeries.net/PDFs/JE5027-99.pdf>

# APPENDIX C

## Instrument Panel / PC Board Detail: AT10.1 Group I Battery Charger w/Optional Auxiliary Alarm Relay PC Board (JE5030-19)

- INDICATOR LIGHTS (LEDs):
- |                                     |                                |
|-------------------------------------|--------------------------------|
| DS01 - GREEN - AC ON                | DS10 - RED - LOW LEVEL DETECT  |
| DS02 - RED - DC VOLTS               | DS11 - RED - (METER DISPLAY)   |
| DS03 - RED - DC AMPS                | DS12 - RED - (METER DISPLAY)   |
| DS04 - RED - EQUALIZE HRS REMAINING | DS13 - RED - HIGH DC VOLTAGE   |
| DS05 - GREEN - FLOAT                | DS14 - RED - LOW DC VOLTAGE    |
| DS06 - AMBER - EQUALIZE             | DS15 - RED - DC OUTPUT FAILURE |
| DS07 - AMBER - MANUAL TIMER         | DS16 - RED - AC INPUT FAILURE  |
| DS08 - AMBER - MANUAL EQUALIZE      | DS17 - RED - POSITIVE GROUND   |
| DS09 - AMBER - AUTO EQUALIZE TIMER  | DS18 - RED - NEGATIVE GROUND   |

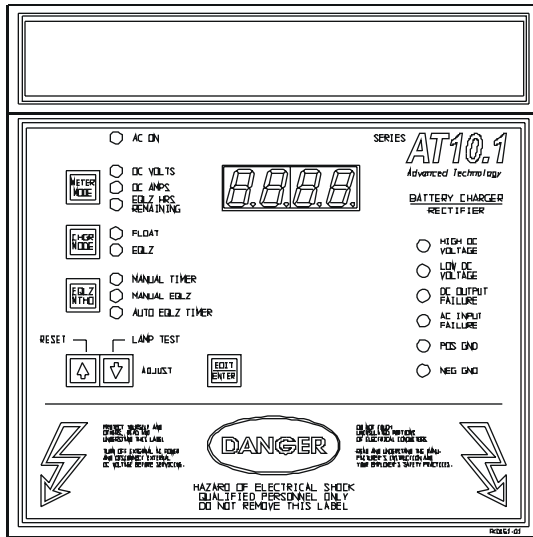

INSTRUMENT PANEL  
(PART No. FK0151-01)

NOTE: UNLESS OTHERWISE SPECIFIED, ALL ALARM TERMINAL BLOCKS (TB3/TB4/TB8) ARE SOLDERLESS COMPRESSION TERMINALS. CONTACT RATING IS 0.5A @ 125VAC/DC, ACCEPTING #22-14 AWG WIRE.

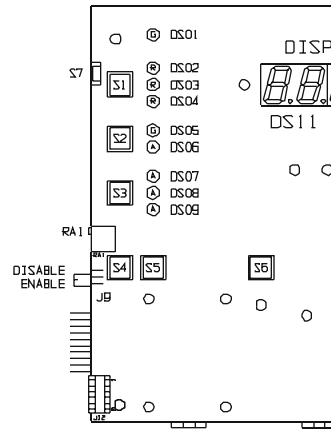

MAIN CONTROL PC BL  
FRONT VIEW - FACING CHARGER C

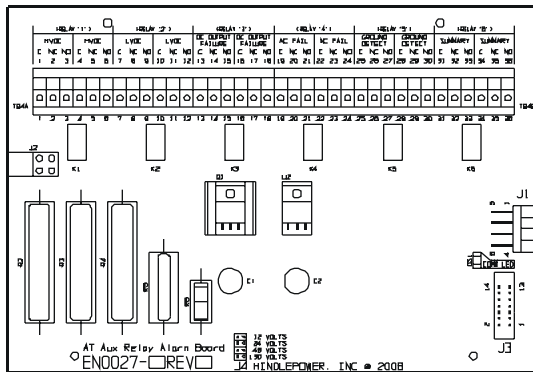

AUXILIARY ALARM RELAY PC BOARD (A5)

A5-J1 CONNECTED TO  
A1-J2 VIA EHS045-XX  
8-PIN SERIAL CABLE

- OTHER CONTROLS:
- RA1 - LOW LEVEL DETECT ADJUST
  - RA2 - GROUND FAULT BALANCE
  - RA3 - GROUND FAULT SENSITIVITY

- NON-USER ACCESSED JUMPERS:
- J3 - CLO A5 RIBBON CONNECTOR
  - J12 - BOARD PROGRAMMING
  - J14 - CLO FORCED LOAD SHARING
  - J15 - MANUFACTURING TEST
  - J16 - CLO INTERNAL TEMP

**NOTICE** This instrument panel drawing (JE5030-19) depicts the optional Auxiliary Alarm Relay PC Board (A5), which provides two (2) sets of discrete form-C contacts (TB4) for the main AT alarm conditions. All AT10.1s feature one (1) set of form-C "summary" (common) alarm contacts (TB3 on A1).

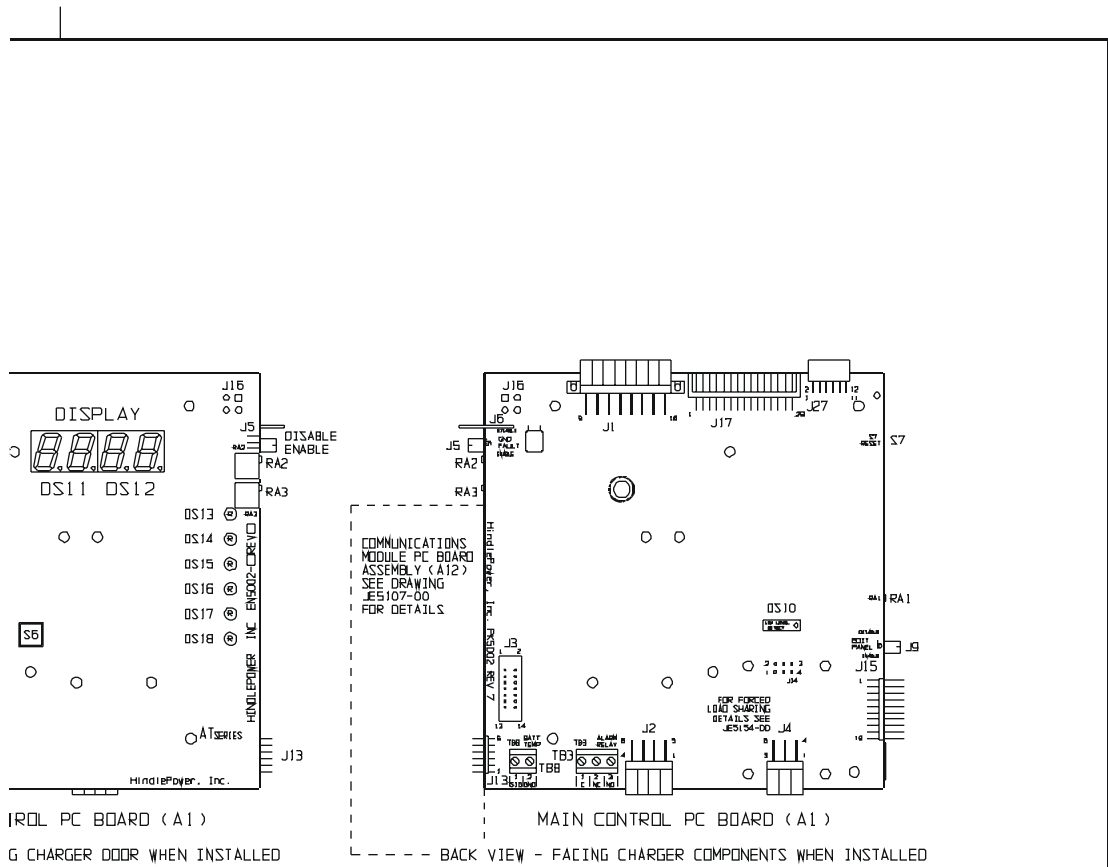

INSTRUMENT PANEL (A1)  
 G CHARGER DOOR WHEN INSTALLED

MAIN CONTROL PC BOARD (A1)  
 --- BACK VIEW --- FACING CHARGER COMPONENTS WHEN INSTALLED

**USER JUMPERS:**

- J1 - MAINFRAME SIGNAL HARNESS
- J2 - AUX ALARM RELAY BOARD (AS) SERIAL CONNECTOR
- J4 - FORCED LOAD SHARING CABLE INTERCONNECTOR
- J5 - GROUND FAULT ENABLE/DISABLE
- J6 - EARTH GROUND CONNECTOR
- J9 - FRONT PANEL ENABLE/DISABLE (LOCKOUT)
- J13 - COMMUNICATIONS PC BOARD (A12) INTERCONNECTOR
- J17 - HD GATE DRIVER PC BOARD (A11) INTERCONNECTOR
- J27 - NOT USED (3PH GATE DRIVER PCB INTERCONNECTOR)
- J29 - (future)

**SWITCHES:**

- S1 - METER MODE
- S2 - CHARGER MODE
- S3 - EQUALIZE METHOD
- S4 - Δ ADJUST
- S5 - ∇ ADJUST
- S6 - EDIT / ENTER
- S7 - PROCESSOR MANUAL RESET

**TERMINAL BLOCKS:**

- TB3 - SUMMARY ALARM RELAY CONTACTS
- TB4 - AUX ALARM RELAY CONTACTS
- TB8 - OPTIONAL TEMPCO PROBE (A10) INTERCONNECTOR

- CONTROLS:**
- LOW LEVEL
  - DETECT ADJUST
  - GROUND FAULT
  - BALANCE
  - GROUND FAULT
  - SENSITIVITY

- ED JUMPERS:**
- ED1 - GROUND FAULT
  - ED2 - GROUND FAULT
  - ED3 - GROUND FAULT
  - ED4 - GROUND FAULT
  - ED5 - GROUND FAULT
  - ED6 - GROUND FAULT
  - ED7 - GROUND FAULT
  - ED8 - GROUND FAULT
  - ED9 - GROUND FAULT
  - ED10 - GROUND FAULT
  - ED11 - GROUND FAULT
  - ED12 - GROUND FAULT
  - ED13 - GROUND FAULT
  - ED14 - GROUND FAULT
  - ED15 - GROUND FAULT
  - ED16 - GROUND FAULT
  - ED17 - GROUND FAULT
  - ED18 - GROUND FAULT
  - ED19 - GROUND FAULT
  - ED20 - GROUND FAULT
  - ED21 - GROUND FAULT
  - ED22 - GROUND FAULT
  - ED23 - GROUND FAULT
  - ED24 - GROUND FAULT
  - ED25 - GROUND FAULT
  - ED26 - GROUND FAULT
  - ED27 - GROUND FAULT
  - ED28 - GROUND FAULT
  - ED29 - GROUND FAULT
  - ED30 - GROUND FAULT
  - ED31 - GROUND FAULT
  - ED32 - GROUND FAULT
  - ED33 - GROUND FAULT
  - ED34 - GROUND FAULT
  - ED35 - GROUND FAULT
  - ED36 - GROUND FAULT
  - ED37 - GROUND FAULT
  - ED38 - GROUND FAULT
  - ED39 - GROUND FAULT
  - ED40 - GROUND FAULT
  - ED41 - GROUND FAULT
  - ED42 - GROUND FAULT
  - ED43 - GROUND FAULT
  - ED44 - GROUND FAULT
  - ED45 - GROUND FAULT
  - ED46 - GROUND FAULT
  - ED47 - GROUND FAULT
  - ED48 - GROUND FAULT
  - ED49 - GROUND FAULT
  - ED50 - GROUND FAULT

			 THIRD ANGLE PROJECTION				
3	21922	120209	DRAWN BY	MCR	022003	TITLE AT10.1 SERIES BATTERY CHARGER (GROUP I)	
2	21097	041108	APPROVED	<i>[Signature]</i>	022003	INSTRUMENT PANEL / PC BOARD DETAIL (OPTIONAL)	
1	E2044	051705	UNLESS OTHERWISE NOTED DIMENSIONS ARE IN INCHES. TOLERANCES ARE:			DRAWING No	JE5030-19
0	E1141	022003				REV	3
REV	ECN No	DATE	SCALE	NTS	PART No	JE5030-19	SHEET 1 OF 1

<http://www.ATSeries.net/PDFs/JE5030-19.pdf>

# APPENDIX C

## Schematic: AT10.1 Group I Battery Charger Standard w/o Options (JE5031-00)

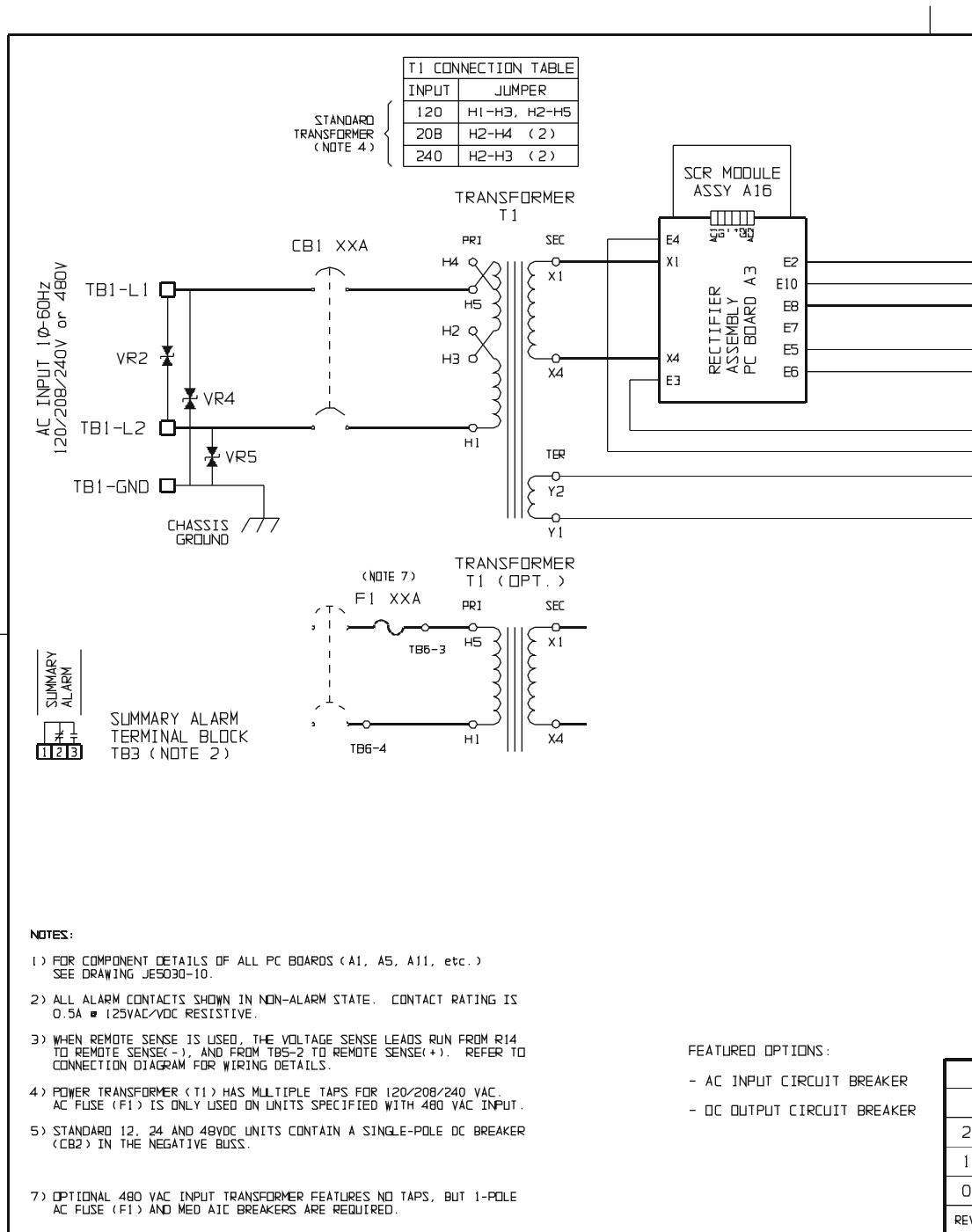



# APPENDIX C

## Schematic: AT10.1 Group I Battery Charger w/Common Options (JE5031-99)

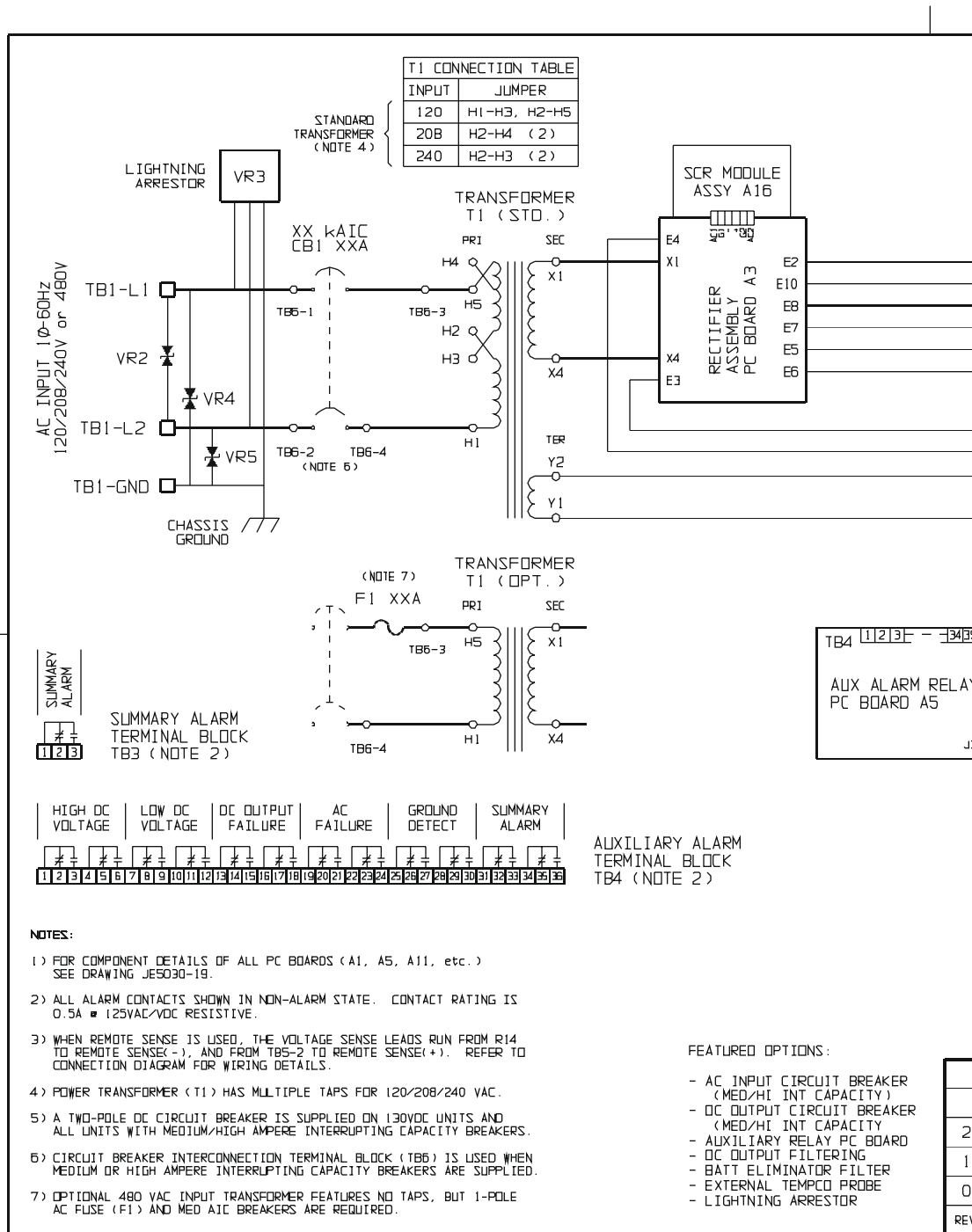



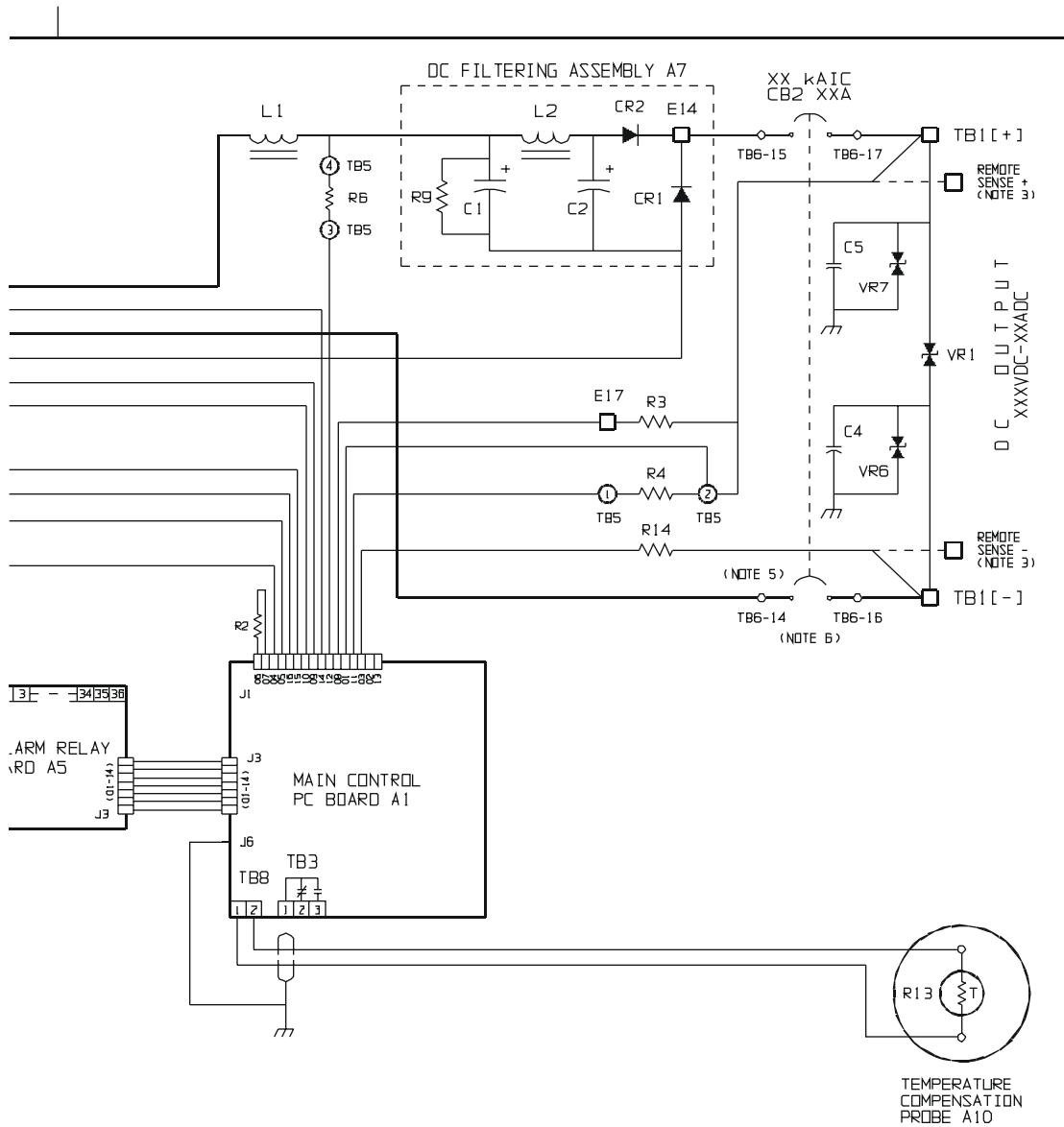

(SER) ) KER  1RD  2				THIRD ANGLE PROJECTION			
	2	E1742	091004	DRAWN BY MCR APPROVED <i>[Signature]</i>	022003	TITLE AT10.1 SERIES BATTERY CHARGER: SCHEMATIC: 6-25ADC (GROUP I) W/COMMON OPTIONS	
	1	E1203	040703	<i>[Signature]</i>	022003	DRAWING No JE5031-99	REV 2 <b>B</b>
	0	E1142	022003	<i>[Signature]</i> UNLESS OTHERWISE NOTED DIMENSIONS ARE IN INCHES. TOLERANCES ARE:		SCALE NTS	PART No JE5031-99 SHEET 1 OF 1
REV	ECN No	DATE	APP				

<http://www.ATSeries.net/PDFs/JE5031-99.pdf>

# APPENDIX C

## Connection Diagram: AT10.1 Group I Battery Charger Standard w/o Options (JE5033-00)

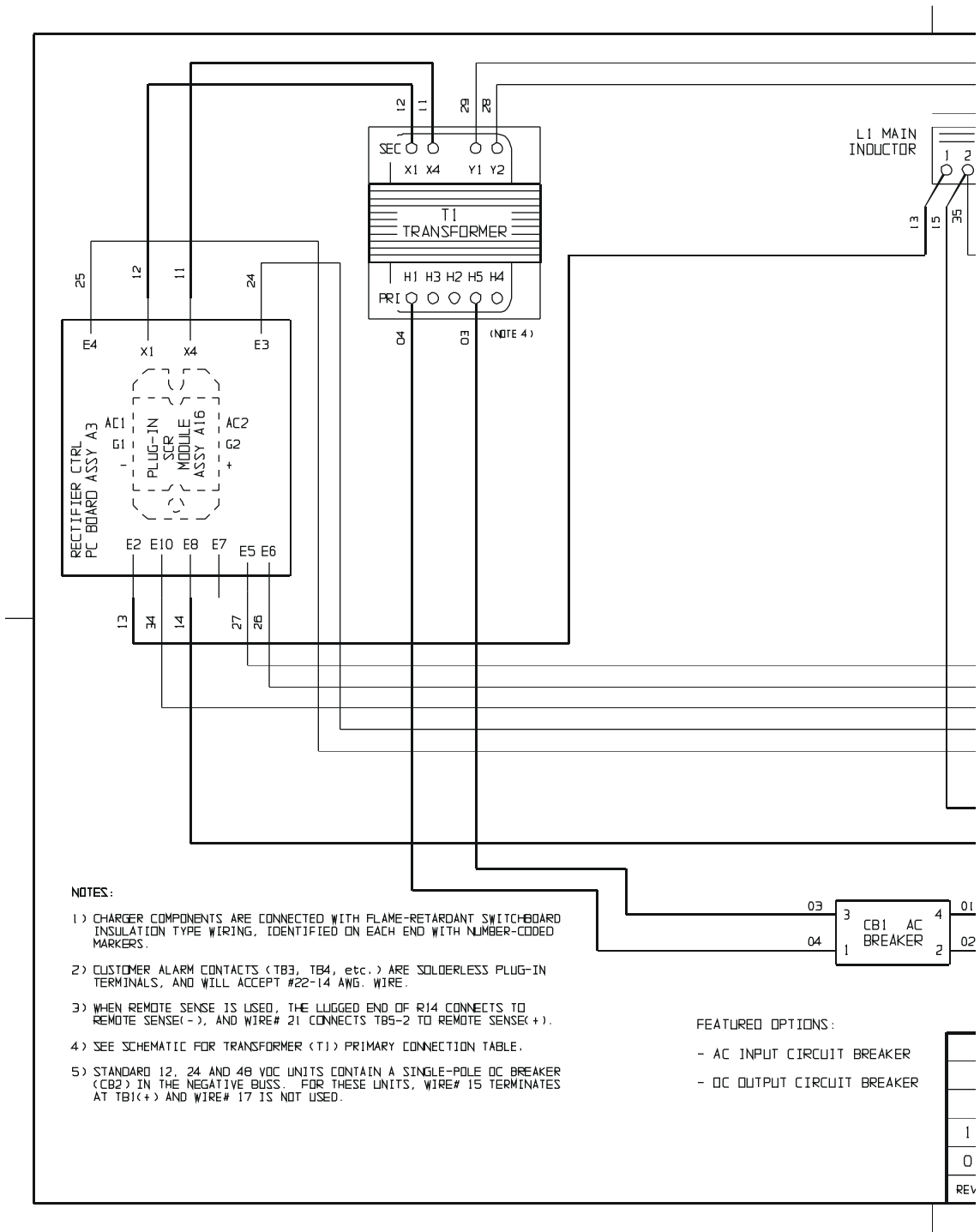

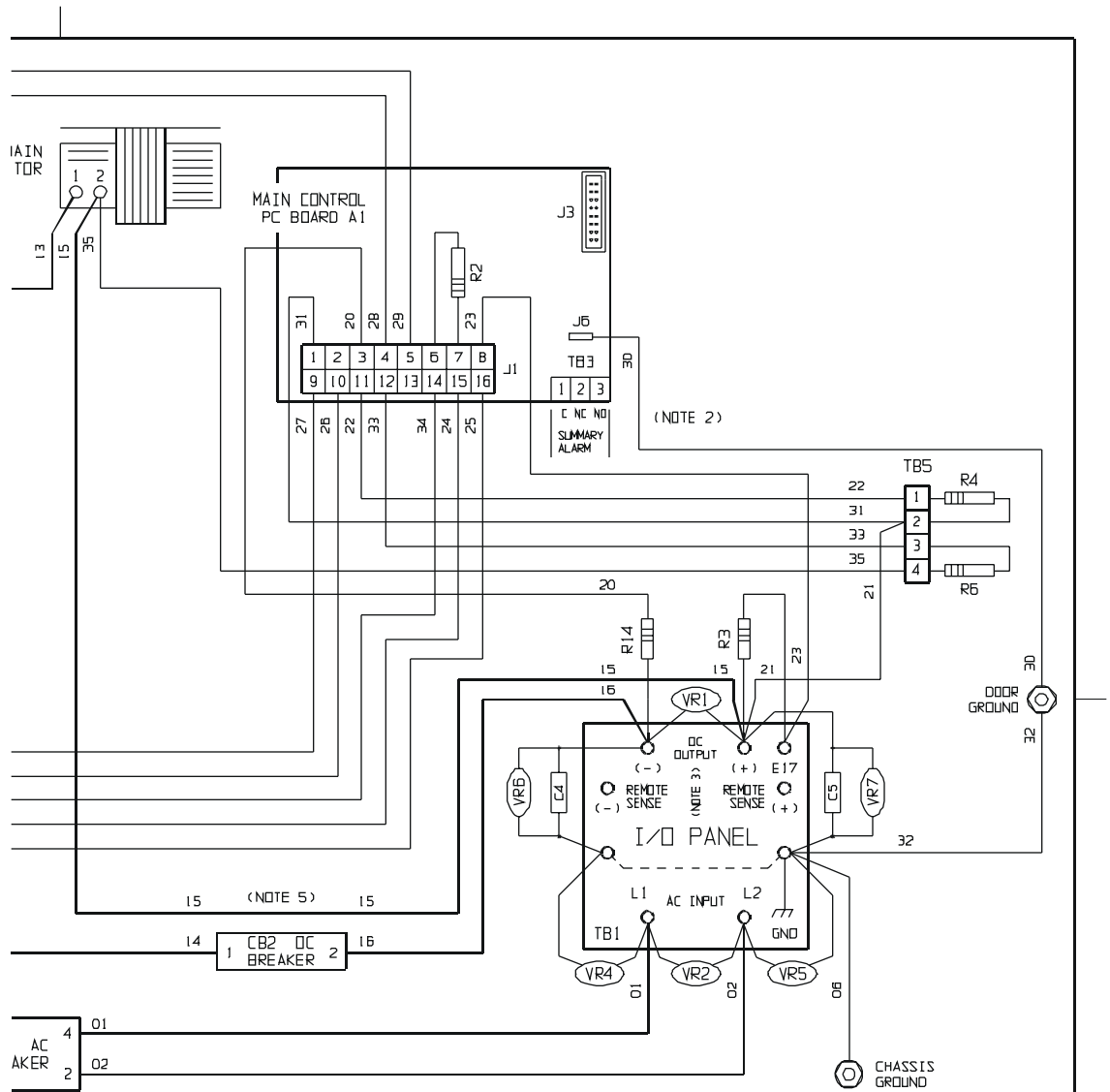

DESIGNER					 THIRD ANGLE PROJECTION	TITLE AT10.1 SERIES BATTERY CHARGER: CONN DIAG: 6-25ADC (GROUP I) STD - W/O OPTIONS					
DRAWN BY	MCR	040703									
REV 1	E1742	091004			APPROVED		040703	DRAWING No	JE5033-00	REV 1	<b>B</b>
REV 0	E1204	040703			UNLESS OTHERWISE NOTED DIMENSIONS ARE IN INCHES. TOLERANCES ARE:			SCALE	NTS	PART No	JE5033-00
								SHEET	1	OF	1

<http://www.ATSeries.net/PDFs/JE5033-00.pdf>

# APPENDIX C

## Connection Diagram: AT10.1 Group I Battery Charger w/Common Options (JE5033-99)

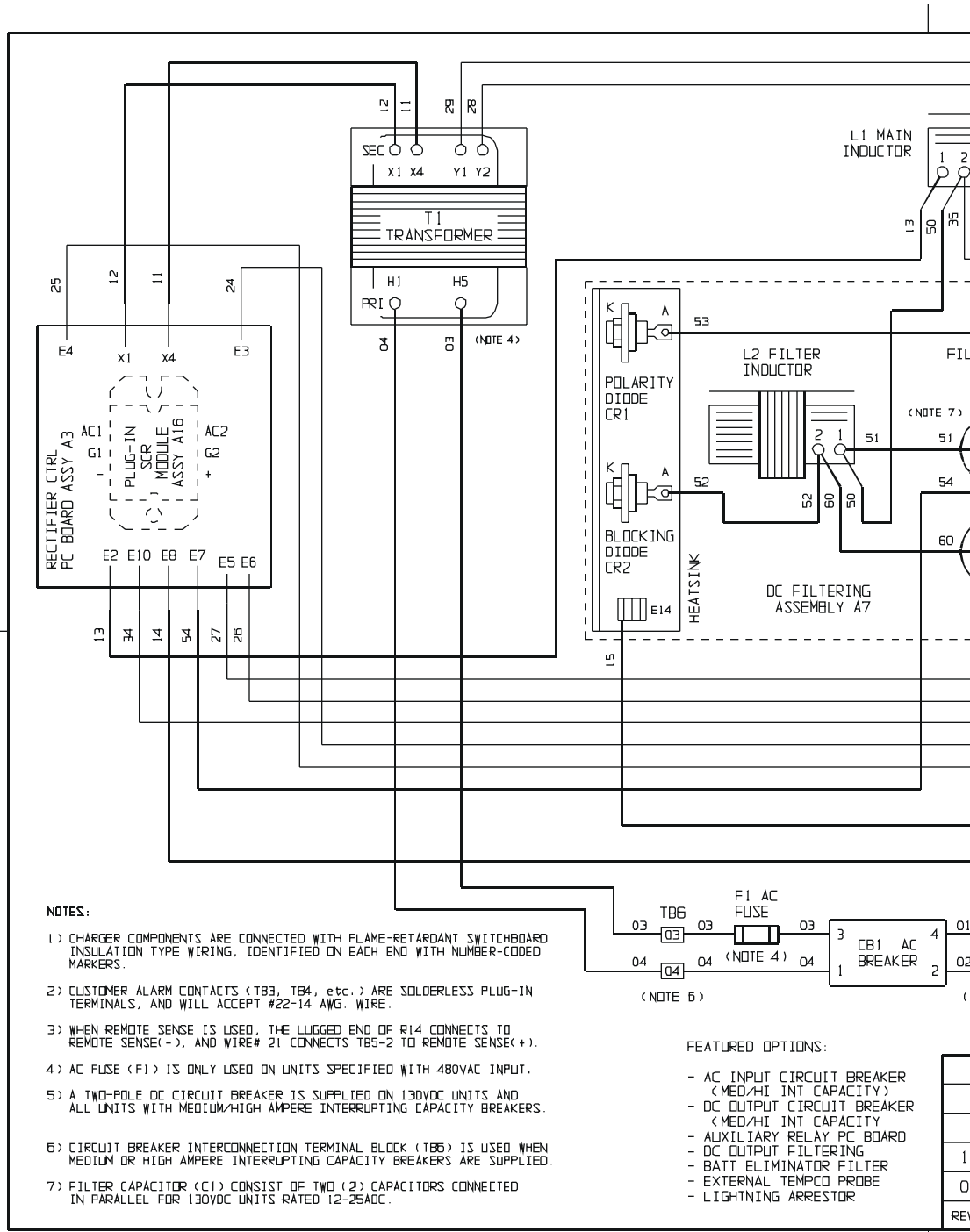

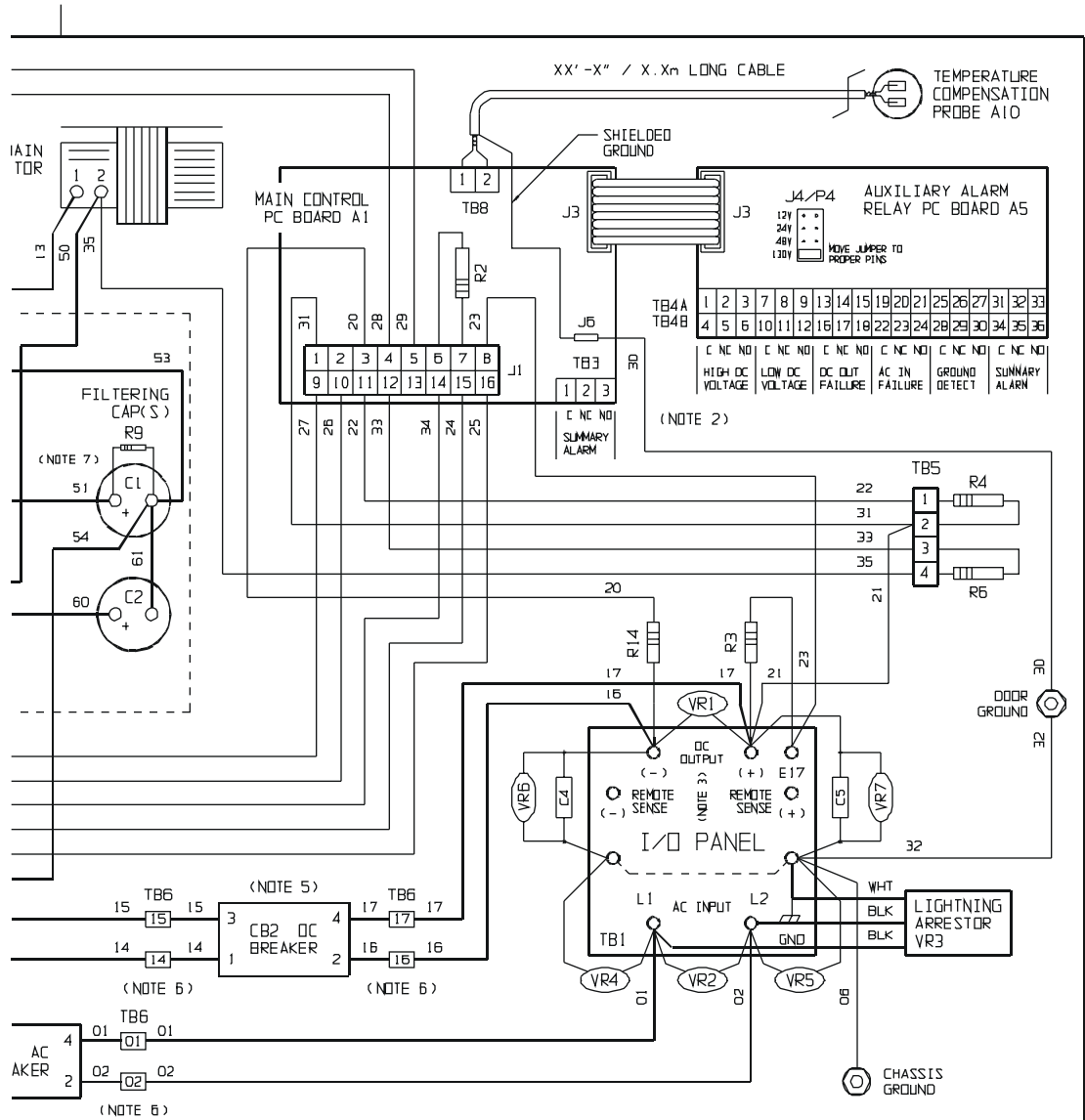

<p>THIRD ANGLE PROJECTION</p> <p>DRAWN BY MCR 040703</p> <p>APPROVED <i>[Signature]</i> 040703</p> <p>UNLESS OTHERWISE NOTED DIMENSIONS ARE IN INCHES. TOLERANCES ARE:</p>	<p>TITLE AT10.1 SERIES BATTERY CHARGER: CONN DIAG: 6-25ADC (GROUP I) W/COMMON OPTIONS</p> <p>DRAWING No JE5033-99</p> <p>SCALE NTS</p>
<p>REV 1</p> <p>ECN No DATE APP</p>	<p>REV 1 B</p> <p>PART No JE5033-99</p> <p>SHEET 1 OF 1</p>

## APPENDIX D

### RECOMMENDED FLOAT AND EQUALIZE VOLTAGES

This table contains suggested values for commonly used batteries. Consult your battery manufacturer's documentation for specific values and settings for your battery type.

Battery Cell Type		Recommended Float Voltage/cell	Recommended Equalize Voltage/cell
Lead-Acid Types	Antimony (1.215 Sp. Gr.)	2.17	2.33
	Antimony (1.250 Sp. Gr.)	2.20	2.33
	Selenium (1.240 Sp. Gr.)	2.23	2.33 - 2.40
	Calcium (1.215 Sp. Gr.)	2.25	2.33
	Calcium (1.250 Sp. Gr.)	2.29	2.33
	Absorbed / Gelled Electrolyte * (sealed lead-acid type)	2.25	*
Nickel-Cadmium (Ni-Cd)		1.42	1.47

\* Sealed lead-acid batteries should not be used in ambient temperatures above 95 °F / 35 °C, and should not normally be equalized. Consult your battery manufacturer's documentation for specific equalizing recommendations.

### TEMPERATURE COMPENSATION

If your batteries are to see temperature variations during charging, a temperature compensation option (**EJ5033-0#**) is recommended. If this option is not part of your AT10.1, manual adjustments should be made. Refer to the equation and table below for temperature-adjusted voltages.

$$\text{temperature-adjusted voltage} = \text{charge voltage} \times K$$

Temperature (°F)	Temperature (°C)	K (Lead-Acid)	K (Nickel-Cadmium)
35	1.7	1.058	1.044
45	7.2	1.044	1.034
55	12.8	1.031	1.023
65	18.3	1.017	1.013
75	23.9	1.003	1.002
77	25.0	1.000	1.000
85	29.4	0.989	0.992
95	35.0	0.975	0.981
105	40.6	0.961	0.970

**COMMUNICATIONS MODULE**

**ONLINE SUPPLEMENTS**

Operating Instructions <http://www.ATSeries.net/PDFs/JA0102-04.pdf>  
 Field Installation <http://www.ATSeries.net/PDFs/JD5008-00.pdf>

**OVERVIEW**

Your AT10.1 Microprocessor-controlled Float Battery Charger features provisions for an optional Communications Module which allows user's to remotely monitor and control the charger over a serial connection. This option supports **DNP3 Level 2** and **Modbus** protocols over **RS-232** or **RS-485** half-duplex. With this option installed, industry-standard Supervisory Control And Data Acquisition (**SCADA**) systems will be able to control, monitor, and log the events of the AT10.1.

Using the Communications Module option, all features of the AT10.1 front instrument panel display are accessible remotely. Remote battery temperature (°C) monitoring is also available with the Communications Module. This particular feature is *not* accessible from the standard AT10.1 front panel display.

Installed from the factory, the AT Series Communications Module (option p/n **EJ5037-0#**), includes a Communications PC Board (A12) with a dc power supply ballast resistor (R29). A special AT Series Communications Module Operating Instructions ([JA0102-04](#)), and field installation instructions ([JD5008-00](#)), are also provided for user support. A field retrofit kit (p/n **EJ5037-1#**) for AT Series Communications is also available for AT10.1s installed and already in use.

An optional Ethernet Gateway interface for AT Series Communication is available for either DNP3 Level 2, or Modbus protocols. Also available is a fiber optic modem kit with interconnection cable. Contact your sales representative to place an order for the AT Series Communication Module and/or accessories. Refer to the table below for ordering information.

Description	Part No.
Installed Communications Option for <b>12 Vdc</b> AT10.1	EJ5037-01
Installed Communications Option for <b>24 Vdc</b> AT10.1	EJ5037-02
Installed Communications Option for <b>48 Vdc</b> AT10.1	EJ5037-03
Installed Communications Option for <b>130 Vdc</b> AT10.1	EJ5037-04
Spare A12 Communications PC Board ( <b>EN5004-00</b> )	EJ1243-12
Field Kit Communications Module for <b>12 Vdc</b> AT10.1	EJ5037-11
Field Kit Communications Module for <b>24 Vdc</b> AT10.1	EJ5037-12
Field Kit Communications Module for <b>48 Vdc</b> AT10.1	EJ5037-13
Field Kit Communications Module for <b>130 Vdc</b> AT10.1	EJ5037-14
Ethernet Gateway Interface for Modbus AT Comm	EJ5226-0#
Ethernet Gateway Interface for DNP3 L2 AT Comm	EJ5226-1#
Fiber Optic Modem w/Interface for AT Comm	EJ5230-0#

# APPENDIX F

---

## FORCED LOAD SHARING

### ONLINE SUPPLEMENT

<http://www.ATSeries.net/PDFs/JA5054-00.pdf>

### INTRODUCTION

Multiple battery chargers are sometimes employed in dc power systems to provide redundancy. Two (2) or more chargers of the same voltage rating can be connected in parallel, each of them capable of powering the connected dc load and charging the battery. If a battery charger should fail during normal operation, the parallel charger can continue to supply the entire required dc load current, and maintain charge on the battery.

When two (2) AT10.1s operate in parallel, they normally will not share the load current equally. Since any two chargers will have slightly different characteristics, one of the two chargers in a system will have a slightly higher dc output voltage, and will therefore assume more of the burden of providing necessary load current. This section describes an optional accessory for the AT10.1, which *forces* units to share dc load equally. The accessory (ordering p/n EJ5126-##) consists of an interconnecting cable to provide such communication, and operating instructions.

### SYSTEM REQUIREMENTS

- The forced load sharing feature is designed only to work with two (2) AT10.1 Series battery chargers. You cannot force load sharing with three (3) or more AT10.1s.
- Both AT10.1s must have the same dc voltage & current rating, and have the same dc filtering.
- Both AT10.1s must have the same ac input source and the same phase rotation.
- Both AT10.1s must feature **Rev. 6** (or higher) builds of the Main Control PC Boards (A1), and corresponding (Rev. 6 or higher) software programs.
- Both AT10.1s must use the same the same program version, since the forced load sharing option has not been tested using different program versions in each unit. To view the program version, press the **LAMP TEST** button on the front instrument panel of the AT10.1. When you release the button, the front panel meter displays the version number for 2 seconds.
- The interconnecting signal cable length should be no more than 50ft (15m).

### INSTALLING THE INTERCONNECTION CABLE

The AT Series forced load sharing accessory is normally supplied by the factory with a standard 15ft (4.6m) interconnection cable. A 25ft (7.6m) long cable and a 50ft (15.2m) long cable are also available. The interconnection cable is terminated at each end with a 6-pin connector that mates with the plastic connector (J4) on lower-right corner of the Main Control PC Board (A1). One end of the cable features an extra jumper in the connector, and should be identified for use with the *Secondary* charger. The other end of the cable connects to the *Primary* charger. Either AT10.1 may be selected as Primary or Secondary, but you may wish to choose the unit that is more accessible to be the Primary. The Primary charger controls the dc output voltage of both AT10.1s.

You may run the interconnection cable through conduit if necessary. However, do not run the cable through the same conduit with power wiring. Do not remove the connectors in order to "fish" the cable through the conduit. Maximum pulling tension is 46 lb. (20.9kg). The cable has a plenum-rated outer jacket, and passes the NFPA 262 flame propagation test. Install the cable between the AT10.1s, and anchor it in place at both ends before connecting. Connect each end to the Main Control PC Boards (A1), inserting the connector into J4 until it is completely seated.

### NOTICE

Power cabling for the battery charger, battery, and dc load interconnection is *not* supplied with the AT10.1 or the AT Series Forced Load sharing option. All user-supplied system wiring should meet National Electric Code (NEC) standards, as well as local/site codes. Confirm polarity of all dc cabling before making connections.



## OPERATING THE AT10.1 WITH FORCED LOAD SHARING

Restore external power connections to both AT10.1s, and restart according to the normal procedure in the AT10.1 Operating and Service Instructions. After the AT10.1s restart, the Primary charger attempts to establish communication with the Secondary. If communication is successful, the AT10.1s behave as follows:

- The Primary charger displays the message **LS-P** (Load Share, Primary) on the front panel meter, alternating with the normal display of output voltage and current.
- The Secondary charger displays the message **LS-S** (Load Share, Secondary) on the front panel meter, alternating with the normal display of output voltage and current.
- The Primary charger transfers all its set points (float, equalize, alarms, etc.) to the Secondary charger. The Primary charger also controls all set points for both AT10s. While in Forced Load Sharing mode, you may adjust any set points (of the charger pair) at the front panel of the Primary. The front panel of the Secondary charger won't allow any settings to be changed.
- If one charger loses ac power (or is turned off), the remaining charger returns to independent operation, whether it was originally the Primary or Secondary.
- If an alarm occurs, both AT10s revert to independent operation for the duration of the alarm.
- In the event of a fault in the interconnection, or any other problem with communication, the AT10.1s return to independent operation, and the front panel on each charger displays the message **E 14**, indicating the fault.
- There is a delay (up to 4 seconds) for the two (2) AT10.1s to establish forced load sharing communication. If communication is broken (or power is lost for one charger), there is a 2-4 second delay for the other charger to resume independent operation.
- If you need to interchange the Primary and Secondary chargers, simply reverse the interconnection cable.
- The presence of the interconnection cable (with proper orientation) forces the two AT10.1s into load sharing. Controlling load sharing from the front panel is neither necessary nor possible.
- **⚠ CAUTION** Never separate the AT10.1 from the dc bus while in forced load sharing mode.

## WHEN TEMPERATURE COMPENSATION IS INSTALLED

The AT Series forced load sharing feature is compatible with the AT Series external temperature compensation accessory. Both AT10.1s must have a temperature probe installed, and the probes should be located as close as possible to each other. When AT10.1s are load sharing, the primary charger will determine the temperature-compensated voltage, and adjust the output accordingly. The voltage displayed by the master and secondary may be different, if either temperature probe is defective or not installed. A slight difference in the displayed voltages may also occur if the two (2) probes are not located in close proximity of each other. See user *Application Note* ([JD5003-00](#)) for further details regarding temperature compensation.

## TROUBLE SHOOTING

If the AT Series Forced Load Sharing option is installed, but the output currents of the AT10.1s are unequal, refer to the following table.

PROBABLE CAUSE	RECOMMENDED ACTION
1. Connection cable missing or installed incorrectly. 2. Incorrect connections to ac power sources. 3. Defective or improper Main Control Board (A1)	1. Ensure that the interconnection signal cable assembly is properly installed, and that the connector for the <b>Secondary</b> charger has the jumper as described at the top of page 3. 2. Ensure that both AT10.1s are connected to the same ac supply and that source phase rotation is the same for both chargers. 3. Replace the Main Control PC Board (A1) in one charger at a time, noting system requirements, to restore correct load sharing operation.

# APPENDIX G

## CE COMPLIANCE - PROPER GROUNDING

- It is the responsibility of the *installer* of the AT10.1 to supply suitable grounding and approved ground wire.
- The AT10.1 chassis must be grounded in accordance with the national electrical codes of the country where installed.
- The ground wire must be approved for use in the country in which the AT10.1 is installed, or bear the ◀ **HAR** ▶ mark.
- A separate bi-color ground wire (green with a 30% yellow stripe) must be run in hard-pipe conduit along with ac supply wiring.
- There must be no switches, splices, or over-current protection in the ground wire.
- Refer to the Data Nameplate Decal affixed to the outside panel of the AT10.1 to determine maximum available operating current.

## UL DATA

<b>⚠ CAUTION</b>				
To operate this battery charger from inputs other than 120 Vac, you must use branch circuit protection. To reduce the risk of fire, use only on circuits provided with the following branch circuit protection in accordance with the National Electrical Code, ANSI/NFPA 70.				
Current Rating	Voltage Rating			
	48 Vdc	130 Vdc	48 Vdc	130 Vdc
12 Adc	---	25A	---	20A
16 Adc	15A	25A	12A	20A
20 Adc	20A	30A	15A	30A
25 Adc	25A	40A	20A	35A
	<b>208 Vac Branch Circuit Protection (Amperes)</b>		<b>240 Vac Branch Circuit Protection (Amperes)</b>	
This table does not apply to units with 480 Vac input.				

## REMOTE SHUTDOWN

### BACKGROUND

**⚠ WARNING** Charging stationary batteries can produce explosive gases! Some installations require the charging process to stop when these gases are detected. The AT10.1 features a remote shutdown capability, allowing the *charging function* to be temporarily halted, using an external user-controlled non-powered "dry" contact.

### INSTALLATION

Locally shut down the AT10.1 by manually opening both front panel circuit breakers (CB1/CB2). If possible, lock out all external power to the charger. Open the front panel door and identify the square Main Control PC Board (A1) mounted to the inside surface of the instrument panel. Along the bottom edge of the board are a number of user contacts. Locate the 2-position compression screw terminal block (TB18) at the *center* of the board.

The terminals for remote shutdown connector are labeled "AUXILIARY I/O", and numbered "2" and "3", with position "1" not loaded. The terminal block

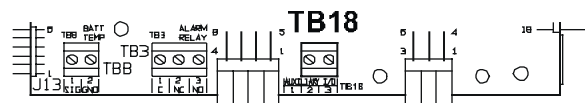

features compression screw connections, accepting #22-14 AWG signal wire.

A user-supplied non-powered "dry" contact is required to activate the AT10.1 remote shutdown feature. Feed user-supplied shutdown wiring into the AT10.1, and route it up to the Main Control PC Board (A1). Strip 0.25in / 6.4mm of insulation from the incoming signal wiring, and insert into terminal block (TB18-2 & TB18-3). Polarity of user shutdown wiring is not important. Tighten the compression screws, and secure the new wiring to the existing signal harness. Return any safety shields and close the front panel door.

Restart the AT10.1 using the procedure in Section 2.1. After the start-up sequence, confirm the AT10.1 returns to normal operating conditions. No alarm indicator LEDs should be lit, and no front panel error codes should be apparent on the 4-digit meter display.

### FUNCTION

Test (or activate) the remote shutdown feature by connecting (or closing) the Auxiliary I/O contacts (TB18-2 and TB18-3). The front panel display should stay lit. Both front panel circuit breakers (CB1/CB2) should stay closed. The 4-digit front panel display should indicate error code **E 16** within seconds. The AT10.1 has been successfully shut down.

**⚠ CAUTION** During remote shutdowns, dangerous voltages still exist inside the AT10.1. External ac power to the input terminals (TB1-L1/L2) are still live, and the ac input circuit breaker (CB1) is closed. Likewise, dc bus voltage is still present at the output terminals (TB1+/-), and the dc output circuit breaker (CB2) is closed.

Initiating a remote shutdown will also cause the AT10.1 summary (common) alarm relay to change state. A discrete alarm contact for remote shutdown is not supplied. However, if the optional AT Series Communications Module is supplied with the charger, the remote shutdown error code (E 16) will be transmitted remotely via Modbus or DNP3.

### RESTART

Restart the AT10.1 by opening Auxiliary I/O contacts (TB18-2 and TB18-3). Error code **E 16** should disappear from the 4-digit front panel display. After a few seconds, the AT10.1 should return to normal operation, and no alarms should be present. The front panel display should alternate between dc output voltage (Vdc) and dc output current (Adc). The AT10.1 has been successfully restarted.

# APPENDIX J

## BATTERY OPEN ALARM

### BACKGROUND

The AT10.1 can be configured to periodically test for an "open battery". This feature allows the AT10.1 to periodically check whether the battery is capable of delivering sufficient output current to satisfy required dc loads for 3 minutes. If the battery is extremely low on capacity, or there is an open string, the Main Control PC Board (A1) will indicate an alarm, alerting the user to capacity test the battery. The benefits of the Battery Open Alarm feature are as follows:

- The test is programmed to run automatically for 3 minutes at 90-day intervals.
- The feature meets, or exceeds, compliance for "*battery continuity confirmation*" as required by the North American Electric Reliability Corporation standard **NERC PRC-005**.
- The test may be easily enabled and disabled on the Main Ctrl PC Board (A1).

### ENABLING/DISABLING

Before enabling or disabling the Battery Open Alarm feature, shut down the AT10.1 by opening both front panel circuit breakers (CB1/CB2). Lock out all ac and dc power from the AT10.1.

Open the front instrument panel door and confirm no voltages are present inside the enclosure. Locate the square Main Control PC Board (A1), mounted to the inside surface of the front panel. Identify shorting jumper (J31), located along the right edge of the board when viewed from the back. Refer to the image on the right.

Move the shorting block onto J31 pins 1-2 to *enable* the Battery Open Alarm feature. Move the shorting block onto J31 pins 2-3 to *disable* Battery Open Alarm. Restart the AT10.1 per Section 2.1.

### FUNCTION

The AT10.1 Battery Open Alarm feature tests the battery at a fixed interval. The test runs automatically every 90 days. The 90-day timer will reset (restart) under any of the following conditions:

- a) The timer will reset on an ac failure.
- b) The timer will reset on Equalize (starts at the end of the equalize period).
- c) The timer will reset if the Battery Open test is deactivated by jumper (J31).
- d) The timer will reset when a previous failure (**E 15** code) is reset.
- e) The timer will reset if a manual test is initiated.

The Battery Open *test* runs for a fixed duration of 3 minutes. During the test, the AT10.1 lowers its output to 2 Volts below the LV Alarm point (see *Setting the Low DC Voltage Alarm* on page 33). During the Battery Open test, the text '*test*' is indicated on the front panel display. If the battery supports the standing load for the entire 3 minutes, the test will conclude. The AT10.1 will return to the normal Float setting, and the Battery Open test will run again at the next interval.

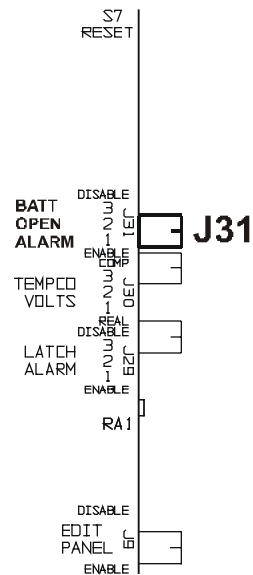

The Battery Open *alarm* will activate if the dc bus falls below LV Alarm point any time during the 3-minute test. The test is immediately terminated when there is an open battery failure. On a failure, error code **E 15** is indicated on the front panel display, and the Summary Alarm relay (TB3) transfers after the nominal 30-second delay. The Battery Open Alarm is latched, but is *independent* of the standard latching alarm setting (see [JA5098-00](#)). If the optional AT Series Communications Module is installed, the Battery Open Alarm (E 15) is also available for SCADA remote monitoring. Code **E 15** will be displayed (latched), and testing is deactivated, until the Battery Open Alarm is reset.

If an optional Auxiliary Alarm Relay PC Board (A5) is supplied with the AT10.1, the redundant Summary Alarm Relay '6' (TB4B, contacts 34/35/36) will be *re-purposed*, from a second Summary Alarm to a dedicated Battery Open Alarm contact. This will only occur if the Battery Open Alarm is enabled via jumper (J31). The standard Summary Alarm relay (TB3) on the Main Control PC Board (A1) will continue to act as a "common" alarm. When the Battery Open Alarm is enabled, redundant relay '6' will transfer *only* on a Battery Open failure. The Battery Open Alarm form-C contacts (TB4B-34/35/36) are latched, independent of the standard latching alarm setting of the optional Auxiliary Alarm Relay PC Board (A5).

To clear the latched alarm(s), press and hold the **RESET** button (**UP** arrow) on the front instrument panel. The AT10.1 will acknowledge the alarm reset by indicating **RStL** on the display. The reset function will clear all latched alarms, and de-activate the Summary Alarm relay contacts (TB3). This will also reset the dedicated Battery Open Alarm contact (redundant relay '6') on the optional Auxiliary Relay PC Board (A5), if installed.

A *manual* Battery Open test can be initiated at any time by holding down the **LAMP TEST** button for longer than 4 seconds, activating the alarm relay(s), see Section 2.2.5 on page 29. The Battery Open Test will run 20 seconds after the **LAMP TEST** key is *released*. This manual test will only work when the Battery Open Alarm jumper (J31) is activated.

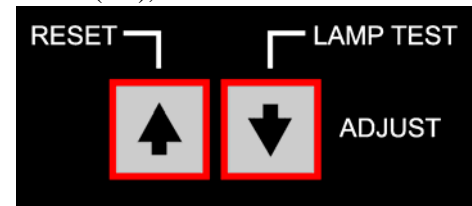

## LIMITATIONS

- The Battery Open Alarm test will work on a stand-alone AT10.1 connected to a single battery, provided that there is sufficient standing load to drop the battery voltage from the Float level during the 3-minute test interval.
- This feature work with a stand-alone AT10.1 connected to a single battery, and also connected to a second similar system through a "Best Battery Selector" (steering diodes). There must be sufficient local load on the battery side of the Best Battery Selector to cause the battery voltage to collapse during the test. The AT10.1 standing load may be sufficient. If the standing load is insufficient, an additional resistive load may need to be permanently connected to each battery, on the battery side.
  - This feature will work on two (2) AT01.1s in Forced Load Sharing. However, only the Primary (master) AT10.1 should have the Battery Open Alarm test enabled. The test will automatically be *deactivated* if it is enabled on a Secondary (slave) AT10.1 in a Forced Load Sharing pair.
  - This feature will *not* work on two (2) AT10.1s, paralleled in "random" (not forced) load sharing, unless one (1) charger is turned off.

# MANUAL SPECIFICATIONS

---

## DOCUMENT NUMBER

The text and graphics contained within this manual are controlled by the battery charger manufacturer's internal part number (**JA5023-00**). The revision level and dates of this manual's text and graphics are listed below. These controls supercede all other available dates. The first two and last two pages of this manual are reserved for company-specific front and back cover artwork. Any revision levels, revision dates, or document numbers featured on the first two and last two pages of this manual refer to the cover artwork only.

## DOCUMENT INFORMATION

Document Number: **JA5023-00**  
Revision Level: **10Q**  
Electronic Filename: **[JA5023-00.Rev10Q.doc]**  
Last Date Saved: **[3/3/2016 5:44 PM]**  
Last Date Printed: **[3/3/2016 5:48 PM]**

## PARTS DATA PACKAGE

Any job-specific customized Parts Data Package report supplied with this battery charger and/or this manual supercedes the information featured in the standard parts list starting on page 64. The data featured in that particular document is applicable only to the battery charger featuring the same serial number listed on the Parts Data Package report.

## DRAWINGS

A customized record drawing package is available for your AT10.1, featuring a unit-specific drawing list / data nameplate detail, outline drawing, itemized internal component layout, electrical schematic with component ratings, and a full connection diagram. If the standard drawings featured in this manual are not sufficient, please contact your Sales Representative for drawing availability from the battery charger manufacturer.

Any job-specific custom drawings supplied with your AT10.1 and/or this manual, supercede the standard drawings featured in Appendix C. The standard drawings and corresponding page numbers featured in this section may not be included with custom printed manuals, when job-specific custom drawings are supplied.

## ONLINE AVAILABILITY



An unlabeled version of this operating and service instruction manual is available online at <http://www.ATSeries.net/PDFs/JA0102-01.pdf>. Other related product operating manuals, feature and accessory special instructions, standard drawings (including the ones listed in this manual), field service instructions, and product application notes for the **AT Series** microprocessor-controlled battery chargers and battery charger products are available online at <http://www.ATSeries.net/>. Saved in Adobe Acrobat Portable Document Format (PDF), they are readily available for downloading and printing.

If revision levels differ between the drawings embedded in this manual and the full online PDF drawings, refer to document with the higher revision level. For document availability of private-labeled manuals and/or standard drawings, please contact your sales representative or visit the web site listed on the **back cover** of this manual.

## RELATED DOCUMENTS

Doc. No.	Online Hyperlink	Description
JC5020-01	<a href="http://www.ATSeries.net/PDFs/JC5020-01.pdf">http://www.ATSeries.net/PDFs/JC5020-01.pdf</a>	AT Series Charger Quick Setup Sheet
<b>JA0102-01</b>	<a href="http://www.ATSeries.net/PDFs/JA0102-01.pdf">http://www.ATSeries.net/PDFs/JA0102-01.pdf</a>	<b>AT10.1 G1 Manual (unlabeled)</b>
JA0102-02	<a href="http://www.ATSeries.net/PDFs/JA0102-02.pdf">http://www.ATSeries.net/PDFs/JA0102-02.pdf</a>	AT10.1 G2 Manual (unlabeled)
JA0102-03	<a href="http://www.ATSeries.net/PDFs/JA0102-03.pdf">http://www.ATSeries.net/PDFs/JA0102-03.pdf</a>	AT30 Manual (unlabeled)
JA0102-04	<a href="http://www.ATSeries.net/PDFs/JA0102-04.pdf">http://www.ATSeries.net/PDFs/JA0102-04.pdf</a>	AT Comm. Module Manual (unlabeled)
JA0102-05	<a href="http://www.ATSeries.net/PDFs/JA0102-05.pdf">http://www.ATSeries.net/PDFs/JA0102-05.pdf</a>	AT-DC Dist Panel Manual (unlabeled)
JA5015-00	<a href="http://www.ATSeries.net/PDFs/JA5015-00.pdf">http://www.ATSeries.net/PDFs/JA5015-00.pdf</a>	AT TempCo Probe Acy. Instructions
JA5054-00	<a href="http://www.ATSeries.net/PDFs/JA5054-00.pdf">http://www.ATSeries.net/PDFs/JA5054-00.pdf</a>	AT Forced Load Sharing Instructions
JA5098-00	<a href="http://www.ATSeries.net/PDFs/JA5098-00.pdf">http://www.ATSeries.net/PDFs/JA5098-00.pdf</a>	AT Latching Alarm Relays Instructions
EJ5088-XX	<a href="http://www.ATSeries.net/PDFs/EJ5088-XX.pdf">http://www.ATSeries.net/PDFs/EJ5088-XX.pdf</a>	AT Series Ground Detection Voltmeter
EJ5130-XX	<a href="http://www.ATSeries.net/PDFs/EJ5130-XX.pdf">http://www.ATSeries.net/PDFs/EJ5130-XX.pdf</a>	AT Series Barrier Type Alarm Terminals
EJ5136-XX	<a href="http://www.ATSeries.net/PDFs/EJ5136-XX.pdf">http://www.ATSeries.net/PDFs/EJ5136-XX.pdf</a>	AT Series Battery Discharge Alarm
EJ5137-XX	<a href="http://www.ATSeries.net/PDFs/EJ5137-XX.pdf">http://www.ATSeries.net/PDFs/EJ5137-XX.pdf</a>	AT Series End Of Discharge Alarm
JA0083-00	<a href="http://www.ATSeries.net/PDFs/JA0083-00.pdf">http://www.ATSeries.net/PDFs/JA0083-00.pdf</a>	AT10.1 Floor-Mtg. Instructions
JA0091-00	<a href="http://www.ATSeries.net/PDFs/JA0091-00.pdf">http://www.ATSeries.net/PDFs/JA0091-00.pdf</a>	AT10.1 St-586/594 Rack-Mtg. Instructions
JA0092-00	<a href="http://www.ATSeries.net/PDFs/JA0092-00.pdf">http://www.ATSeries.net/PDFs/JA0092-00.pdf</a>	AT10.1 St-586/594 NEMA-2 Drip Shield
JA0107-00	<a href="http://www.ATSeries.net/PDFs/JA0107-00.pdf">http://www.ATSeries.net/PDFs/JA0107-00.pdf</a>	AT10.1 St-586/594 Cabinet Heater Acy.
JA0108-00	<a href="http://www.ATSeries.net/PDFs/JA0108-00.pdf">http://www.ATSeries.net/PDFs/JA0108-00.pdf</a>	AT10.1 St-586/594 Cabinet Padlock Acy.
JE5068-00	<a href="http://www.ATSeries.net/PDFs/JE5068-00.pdf">http://www.ATSeries.net/PDFs/JE5068-00.pdf</a>	AT10.1 NEMA-4 Cabinet for St-586/594
JD0064-00	<a href="http://www.ATSeries.net/PDFs/JD0064-00.pdf">http://www.ATSeries.net/PDFs/JD0064-00.pdf</a>	Preventative Maintenance Procedure
JD0064-01	<a href="http://www.ATSeries.net/PDFs/JD0064-01.pdf">http://www.ATSeries.net/PDFs/JD0064-01.pdf</a>	AT Series Charger Start-up Procedure
JD5003-00	<a href="http://www.ATSeries.net/PDFs/JD5003-00.pdf">http://www.ATSeries.net/PDFs/JD5003-00.pdf</a>	TempCo Probe Application Note
JD5008-00	<a href="http://www.ATSeries.net/PDFs/JD5008-00.pdf">http://www.ATSeries.net/PDFs/JD5008-00.pdf</a>	AT Comm. Module Field Installation
JD5009-00	<a href="http://www.ATSeries.net/PDFs/JD5009-00.pdf">http://www.ATSeries.net/PDFs/JD5009-00.pdf</a>	AT10.1 G1 Rectifier Field Installation
JD5010-00	<a href="http://www.ATSeries.net/PDFs/JD5010-00.pdf">http://www.ATSeries.net/PDFs/JD5010-00.pdf</a>	AT Power Res. (R3) Field Installation
JD5011-00	<a href="http://www.ATSeries.net/PDFs/JD5011-00.pdf">http://www.ATSeries.net/PDFs/JD5011-00.pdf</a>	Ext. Free-Wheeling Diode Application Note
JD5012-00	<a href="http://www.ATSeries.net/PDFs/JD5012-00.pdf">http://www.ATSeries.net/PDFs/JD5012-00.pdf</a>	Main Ctrl PC Board (A1) Field Installation
JD5014-00	<a href="http://www.ATSeries.net/PDFs/JD5014-00.pdf">http://www.ATSeries.net/PDFs/JD5014-00.pdf</a>	AT10.1 St-586/594 Encl. Keylock Acy.
JD5025-00	<a href="http://www.ATSeries.net/PDFs/JD5025-00.pdf">http://www.ATSeries.net/PDFs/JD5025-00.pdf</a>	AT10.1 G1 Aux Alarm Relay Field Install
JD5037-00	<a href="http://www.ATSeries.net/PDFs/JD5037-00.pdf">http://www.ATSeries.net/PDFs/JD5037-00.pdf</a>	AT Series Ground Bus Bar Field Install
DC5016-00	<a href="http://www.ATSeries.net/PDFs/DC5016-00.pdf">http://www.ATSeries.net/PDFs/DC5016-00.pdf</a>	AT Series AC Input Current Tables
JD0052-00	<a href="http://www.ATSeries.net/PDFs/JD0052-00.pdf">http://www.ATSeries.net/PDFs/JD0052-00.pdf</a>	Battery Discharge Dual Operation Note
JD5002-00	<a href="http://www.ATSeries.net/PDFs/JD5002-00.pdf">http://www.ATSeries.net/PDFs/JD5002-00.pdf</a>	DC Motor Starting Application Note
JD5006-00	<a href="http://www.ATSeries.net/PDFs/JD5006-00.pdf">http://www.ATSeries.net/PDFs/JD5006-00.pdf</a>	Alt. & Temp. De-Rating Application Note
JD5013-00	<a href="http://www.ATSeries.net/PDFs/JD5013-00.pdf">http://www.ATSeries.net/PDFs/JD5013-00.pdf</a>	AC Ripple Specification Application Note
JD5032-00	<a href="http://www.ATSeries.net/PDFs/JD5032-00.pdf">http://www.ATSeries.net/PDFs/JD5032-00.pdf</a>	Ground Fault Detection Application Note
JF5039-00	<a href="http://www.ATSeries.net/PDFs/JF5039-00.pdf">http://www.ATSeries.net/PDFs/JF5039-00.pdf</a>	AT10.1/AT30 3rd Party Agency Approvals
JF5045-00	<a href="http://www.ATSeries.net/PDFs/JF5045-00.pdf">http://www.ATSeries.net/PDFs/JF5045-00.pdf</a>	Proper Sizing of Industrial Battery Chargers

# QUICK SET-UP

**Scan this QR Code...**

**...for a handy guide which will lead you through a quick setup of the industry's most *USER-FRIENDLY* battery charger!**



**QUICK SET-UP SHEET**

**1) LOCATION**  
PLACE THE CHARGER IN A WELL VENTILATED AREA

**2) SAFETY FIRST**  
DISCONNECT AND LOCK-OUT ALL AC SOURCES AND DC BATTERY VOLTAGES

**3) ELECTRICAL CONNECTIONS**  
A) CONNECT AC POWER TO THE CHARGER  
B) CONNECT THE BATTERY OR DC BUS

**4) STARTING THE CHARGER**  
RECHECK YOUR WIRING. IF IT IS CORRECT, FOLLOW THE START SEQUENCE BELOW

**5) SETTING THE PARAMETERS**

# **MDS** POWER<sup>®</sup>

P.O. Box 532, Champlain, New York 12919  
Tel: 514.369.4919 [www.mdspower.com](http://www.mdspower.com)