

INSTALLATION & OPERATION MANUAL

VTC1015 Series Voltage Converter



VOLTAGE CONVERTERS

IMPORTANT SAFETY INSTRUCTIONS

SAVE THESE INSTRUCTIONS — This manual contains important safety and operating instructions for the voltage converter

VOLTAGE CONVERTER PRECAUTIONS

1. Do not expose the voltage converter to rain or snow unless it is a sealed model.
2. Use of an attachment not recommended or sold by the manufacturer may result in a risk of fire, electric shock, or injury to persons.
3. Do not disassemble the voltage converter. If service or repair is required, return it to the manufacturer or an authorized service center. Incorrect reassembly may result in a risk of fire or electric shock. Voltages up to 350 volts are present inside the voltage converter any time it is connected to input power, even if it is switched OFF.
4. To reduce risk of electric shock, disconnect the voltage converter from the input power before attempting any maintenance or cleaning. Switching the voltage converter to OFF will not reduce this risk.
5. Never place the voltage converter directly above a battery; gasses from the battery will corrode and damage the voltage converter.
6. Never allow battery acid to drip onto the voltage converter.

Medical Equipment Notice

Analytic Systems does not recommend the use of their products in life support applications where failure or malfunction of this product can be reasonably expected to cause the failure of the life support device or to significantly affect its safety or effectiveness. Analytic Systems does not recommend the use of its products in direct patient care.

Examples of devices considered to be life support devices are: neonatal oxygen analyzers, nerve stimulators (whether used for anesthesia, pain relief, or other purposes), auto-transfusion devices, blood pumps, defibrillators, arrhythmia detectors and alarms, pacemakers, hemodialysis systems, peritoneal systems, neonatal ventilator incubators, ventilators for both adults and infants, anesthesia ventilators, and infusion pumps as well as any other devices designated as "critical" by the U.S. FDA.

Introduction

The VTC1015 model voltage converter supplies up to 1000 watts of power to a connected load, converting an input of 24, 36, 48 or 72 VDC to a 12, 24 or 24 VDC output.

The unit features full electrical isolation between the input and output to be compatible with positive or negative grounded systems. The output can also be set either to positive to negative ground by connecting the appropriate wire to ground. Proven current mode switching design offers increased power and reliability in a compact package and additional input and output filtering reduce EMI to extremely low levels protecting sensitive electronics from interference.

A bright LED indicator panel shows the unit's operating condition at a glance; these indicators can be duplicated on an optional remote control panel along with an alarm buzzer and secondary on/off switch. In the event of a malfunction, the converter is protected by reliability features including an input fuse, thermal shutdown and current limiting; while the load is safeguarded by an output crowbar circuit.

Optional features include an integrated ammeter/voltmeter display, rack-mount chassis and battery backup.

Main Parts

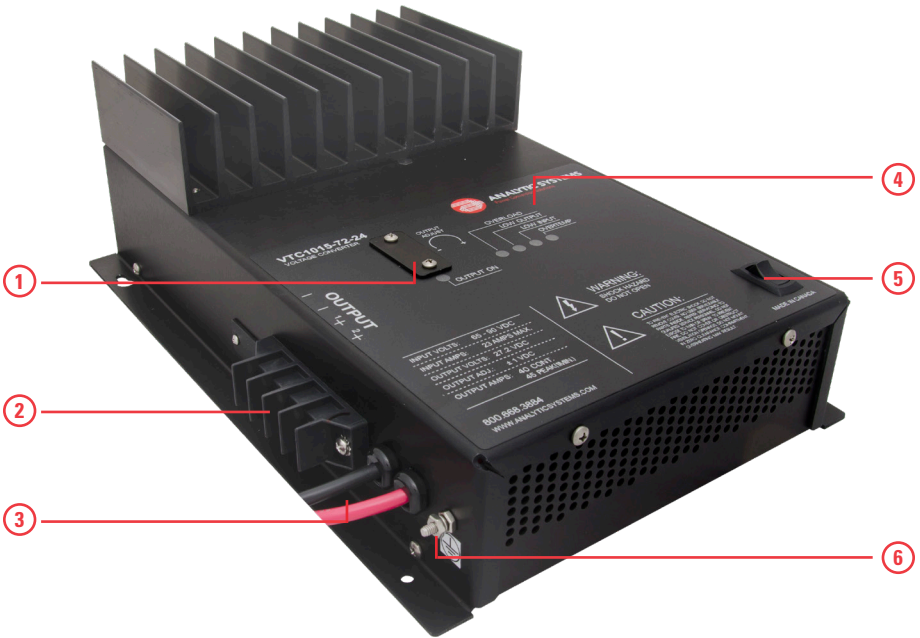

Front Panel

- | | |
|--------------------------|---------------------------|
| 1. Output Voltage Adjust | 4. LED Indicator Panel |
| 2. DC Output Connection | 5. On/Off Toggle Switch |
| 3. DC Input Connection | 6. Chassis Grounding Stud |

Box Contents

The box you have received should contain the following:

- One VTC1015 Voltage Converter
- This manual
- One Warranty Card

If anything is missing or damaged please contact your dealer or Analytic Systems for a replacement

Installation

MOUNTING

Mount the unit in a DRY location. Allow at least 4 inches of clearance around it for adequate cooling.

INPUT CONNECTION

The unit is equipped with 3 foot long (1m) power leads as a DC input connection. This should normally be adequate to connect to a source of power. However, if you must extend the power leads, be sure to use at least a good quality (type TEW) wire of at least the same gauge as supplied with the unit. The wire colours are:

- Red: Positive connection
- Black: Negative connection

All connections should be made inside an appropriate junction box. Refer to the specifications table for the correct sizing of the circuit breaker in the distribution panel. A ground stud is provided to bond the chassis to local ground to reduce or eliminate EMI.

OUTPUT CONNECTIONS

This unit is equipped with two Positive output terminals and two Negative output terminals as DC output connections. Connect only one wire to each terminal. Ensure that the total average load connected does not exceed the continuous current rating of the unit.

To ensure spark free connections the power switch must be in the OFF position prior to making the connections to the load(s).

IMPORTANT: For 12VDC Model Only!

For 12 VDC model, the output terminals must be connected in parallel as shown below if the load current is greater than 50A

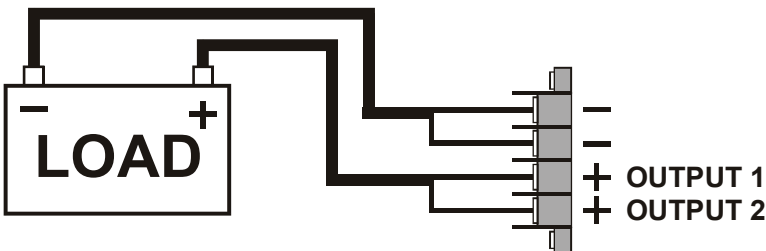

Operation

This unit is designed for simple and intuitive operation. Before you use the unit, make sure the load and power source are correctly connect as shown under *Installation*

TURNING THE UNIT ON AND OFF

To turn the converter on, press the On/Off toggle switch on the top The **Output ON** LED will start glowing green, indicating that the outputs are energized.

To turn the converter off, press the On/off toggle switch to the OFF position. The **Output ON** LED will turn off. Once the unit is off, it is safe to disconnect the power source and/or load.

ADJUSTING THE OUTPUT VOLTAGE

The converter's output voltage can be adjusted over a range of ± 1.0 volt for fine tuning purposes. The unit must be ON, in order to adjust the output voltage.

1. At the load, attach a good quality voltmeter or multimeter to monitor the voltage.
2. Loosen and remove the two screws holding the cover panel to the chassis
3. Remove the cover plate to expose the Output Voltage Adjust potentiometer.
4. Using a very small flat-blade screwdriver, rotate the potentiometer. Rotating it clockwise, increases the output voltage. Rotating counterclockwise, decreases it.
5. Check the reading on the attached voltmeter/multimeter. End adjustment when satisfied.
6. Remove the screwdriver and reattach the cover plate to the chassis.

METERS

A high quality digital meter can be added to the voltage converter (factory installed only). The meter shows simultaneous voltage and current on either of the two output terminals. A toggle switch permits selection between the output terminals. The meter features bright red LED readouts to permit easy monitoring from many feet or meters away.

Dry Contact Relay

To use your dry contact output fail relay you must connect a 9-pin D connector to the unit. You must use pins one and six as is indicated on page 6 in the remote connector diagram.

The relay is factory preset to fail in the closed position when the low output LED and buzzer come on. If you wish to have the relay fail in the open position when the low output LED and buzzer come on, you must take the cover off the unit and move the jumper on J10 to the other position. J10 is located next to the relay K1.



To change the position of the jumper, first turn the unit off and disconnect the unit from both the power and load(s). Next, turn the unit on for 30 seconds to discharge the capacitors, then turn it off again. Remove the eight screws holding on the cover. Turn the unit upside down, remove the cover and locate J10. It will be next to the relay K1 as is shown in the above diagram. Simply move the jumper to the desired position as is shown in the above diagram. Replace the cover and re-install the eight cover screws. Reconnect the unit to the power and load(s).

Remote Control Option



IMPORTANT: This remote is to be used only on Voltage Converters manufactured by Analytic Systems.

A remote control panel may be connected to the voltage converter using a 9-pin D-connector that attaches to the side of the voltage converter. The remote control panel and D connector are part of the remote control option. The remote control panel allows the unit to be operated remotely as well as duplicating all the diagnostic indicators and audible alarm.

Remote Connector

This connector is located on the side of the unit. Important: To prevent the possibility of High Voltage Electrical Shock, do not power up the Voltage Converter unless all wiring from the unit to the remote is securely connected. Do not remove the dust cover from the DB-9 connector if the remote is not being used.

Load Sharing (Option D)

The Load Sharing Option (Option D) allows the unit to be connected in parallel with other voltage converter to power a single load. To accommodate this function, special output isolation diodes are present in the unit to prevent current from back feeding into the unit. In addition, the peak current is lowered to the continuous rating for safety purposes.

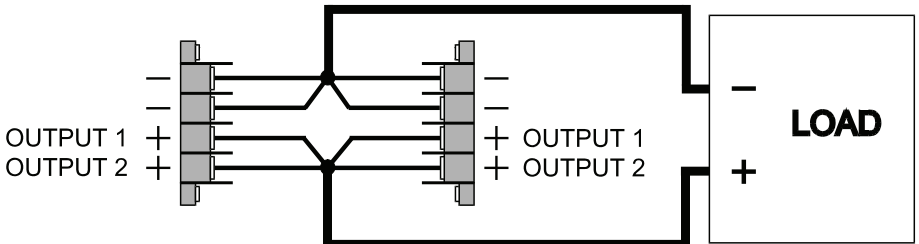

To check if that your unit has these diodes

Use an ohmmeter to measure the resistance between the two positive output terminals.

- If the diodes are present, the terminals will measure as not connected.
- If the diodes are NOT present, the terminals will measure as a short circuit.

Output Voltage (Vdc)	12	24	32	48
Wire Gauge (AWG)	#8	#10	#12	#14

1. Assuming the output isolation diodes are present, connect a one-foot piece of red wire of the appropriate gauge (as shown in the table above) to each positive output terminal.
2. Connect all the positive wires to a distribution bus, or connect them together.
3. Then connect from the common point to the load using the correct gauge of wire for the total output capability of all the supplies running in parallel.

Repeat the above steps for the negative terminals using the same gauges of black wire. These units should now load share, you can use an ohmmeter at the load to confirm this. A slight difference is acceptable. If there is more than a slight difference, then adjust the output voltage as shown under *Operation*.

Battery Backup (Option B)

The Battery Backup Option allows the unit to switch to using a connected battery as a power source in the event of external power failure.

The DC power output normally supplies the load while the battery is maintained at full charge by a 1A trickle charger built into the unit. In the event of an input power failure, the load instantly switches over to using the battery as replacement power source, running until either the battery is fully discharged or the load goes into low voltage shutdown. Once power is restored, the DC output will resume supplying power to the load and the trickle charger will recharge the battery.

To set up the Battery Backup:

1. Connect the Load to the output terminals labelled **OP+** and **OP-**
2. Connect the Battery to the output terminals labelled **Batt+** and **Batt-**
3. Turn the unit ON

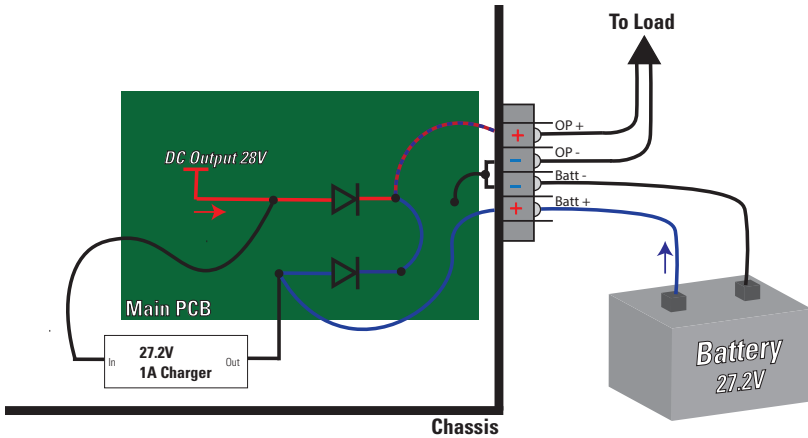

Note: The diagram shows the voltage settings for a 24V system, but this option is available for every standard output voltage.

The Battery Backup circuit is designed so the battery is normally reverse biased. Essentially, whichever source has the higher voltage will take precedence in supplying power to the load. If the Voltage Output (V_{Out}) is greater than the Battery Voltage (V_{Batt}), current will only flow from V_{Out} to the load. The path of this current is indicated in **red**.

If V_{Out} drops below V_{Batt} , the current will flow from the battery to the load. The path of this current is indicated in **blue**. The configuration of the schottky diodes prevents this current from backfeeding into the unit.

TIP: Size your batteries correctly.

Choose batteries with enough amp-hour capacity to power the load for the required amount of time in a power outage.

Troubleshooting

This unit provides LED indicators and a buzzer to help diagnose any problems. The unit should sound the buzzer to alert you prior to shutting itself down. You should immediately check the indicators to determine the cause of the shutdown.

SYMPTOMS	CAUSE
Overload LED is glowing	The current demanded by the load has exceeded the maximum output rating for too long of a time.
FIX:	Check that the connection to the load is intact and not corroded. Reduce the number of devices connected to the voltage converter.
The Overtemp LED is glowing	The voltage converter is running too hot.
FIX:	Check that the load is suitable for the output. The converter may heat up if it is running at its maximum output for too long of a time. Remount the unit for better airflow and ventilation.
Input fuses blown when unit is turned ON	The power source may be connected to the unit with the wrong polarity.
FIX:	Reverse the polarity of the power source connection so it is properly connected. If the polarity is already correct, then the unit is damaged and must be returned for repair.
The Low Input LED is glowing	The unit is not receiving enough power to operate normally.
FIX:	Check that the connection to the power source is intact and not corroded. Check that the power source is properly rated for use with the voltage converter. If there are no power source issues, then the unit is damaged and must be returned for repair.
The Low Output LED is glowing. Overload LED may be glowing	The unit's output voltage has fallen below the range needed for normal operation
FIX:	The current demanded by the load may be causing the output voltage to drop to maintain the current at the maximum level.

Specifications

Input Voltages			
Nominal (ip)	24	48	72
Actual	** 20 – 35	** 40 – 60	** 65 – 90
Input Amps (max)	72.6	36.3	23
Input Fuse	3 x ATC25	2 x ATC20	1 x ATC30

Output Voltages				
Nominal (op)	12	24	32	48
Actual	13.6 ± 0.05V	27.2 ± 0.05V	36.3 ± 0.05V	54.4 ± 0.05V
Output Adjustment	± 1.0 Volts			
Output Amps (cont)	0 – 60	0 – 40	0 – 30	0 – 20
Output Amps (max)	70	45	34	22.5
Output Crowbar	16.0 ± 0.5 V	32 ± 1.0 V	43.7 ± 1.3 V	63.9 ± 2.0 V

General	
Switching Frequency	60 ± 2 KHz
Idle Power	< 10 Watts
Noise on Input	< 50 milli-Volts
Noise on Output	< 50 milli-Volts
Transient Response	< 2V for 50% Surge (Output Amps/2)
Efficiency	> 85 % @ maximum output
Temp. Range	-25 to 40 deg. C @ maximum output
Isolation	Input-Output & Input-Case 1500 Vdc (500 Vdc @ 24 V In), Output-Case 500 VDC (1500Vdc @ 48 V Out)
Dimensions	14.5 x 10.2 x 5.0 in / 37 x 25 x 13 cm
Clearance	1 Inch (2.5 cm) all around
Material	Marine Grade Aluminum
Finish	Black Powder Epoxy
Fastenings	18-8 Stainless
Weight	10.2 lb / 4.7 kg

** Actual startup is at 22, 42, or 67Vdc Input, depending on model

* Specifications subjects to change without notice.

Limited Warranty

1. The equipment manufactured by Analytic Systems Ware (1993) Ltd. (the "Warrantor") is warranted to be free from defects in workmanship and materials under normal use and service.
 2. This warranty is in effect for:
 - a. 3 Years from date of purchase by the end user for standard products offered in our catalog.
 - b. 2 Years from date of manufacture for non-standard or OEM products
 - c. 1 Year from date of manufacture for encapsulated products.
 3. Analytic Systems will determine eligibility for warranty from the date of purchase shown on the warranty card when returned within 30 days, or
 - a. The date of shipment by Analytic Systems, or
 - b. The date of manufacture coded in the serial number, or
 - c. From a copy of the original purchase receipt showing the date of purchase by the user.
 4. In case any part of the equipment proves to be defective, the Purchaser should do the following:
 - a. Prepare a written statement of the nature of the defect to the best of the Purchasers knowledge, and include the date of purchase, the place of purchase, and the Purchasers name, address and telephone number.
 - b. Call Analytic Systems at 800-668-3884 or 604-946-9981 and request a return material authorization number (RMA).
 - c. Return the defective part or unit along with the statement at the Purchasers expense to the Warrantor; Analytic Systems Ware (1993) Ltd., 8128 River Way, Delta, B.C., V4G 1K5, Canada.
 5. If upon the Warrantor's examination the defect proves to be the result of defective material or workmanship, the equipment will be repaired or replaced at the Warrantor's option without charge, and returned to the Purchaser at the Warrantor's expense by the most economical means. Requests for a different method of return or special handling will incur additional charges and are the responsibility of the Purchaser.
 6. Analytic Systems reserves the right to void the warranty if:
 - a. Labels, identification marks or serial numbers are removed or altered in any way.
 - b. Our invoice is unpaid.
 - c. The defect is the result of misuse, neglect, improper installation, environmental conditions, non-authorized repair, alteration or accident.
 7. No refund of the purchase price will be granted to the Purchaser, unless the Warrantor is unable to remedy the defect after having a reasonable number of opportunities to do so.
 8. Only the Warrantor shall perform warranty service. Any attempt to remedy the defect by anyone else shall render this warranty void.
 9. There shall be no warranty for defects or damages caused by faulty installation or hook-up, abuse or misuse of the equipment including exposure to excessive heat, salt or fresh water spray, or water immersion except for equipment specifically stated to be waterproof.
 10. No other express warranty is hereby given and there are no warranties that extend beyond those described herein. This warranty is expressly in lieu of any other expressed or implied warranties, including any implied warranty of merchantability, fitness for the ordinary purposes for which such goods are used, or fitness for a particular purpose, or any other obligations on the part of the Warrantor or its employees and representatives.
 11. There shall be no responsibility or liability whatsoever on the part of the Warrantor or its employees and representatives for injury to any person or persons, or damage to property, or loss of income or profit, or any other consequential or resulting damage which may be claimed to have been incurred through the use or sale of the equipment, including any possible failure of malfunction of the equipment, or part thereof.
 12. The Warrantor assumes no liability for incidental or consequential damages of any kind
-